

Digital Palmcorder®
MultiCam™ Camcorder

Panasonic®

Digital Video Camcorder
Operating Instructions

Model No. **PV-DV102**

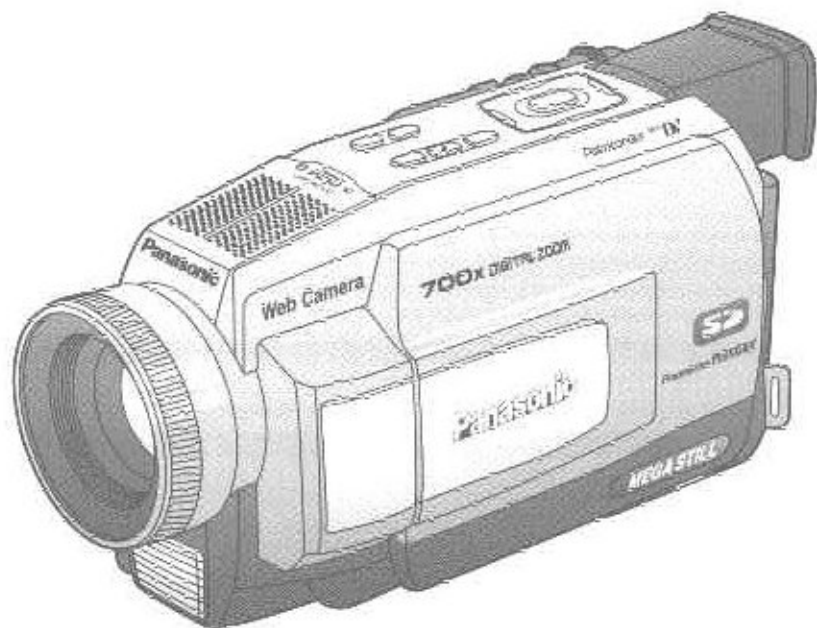

MultiMediaCard™



Mini **DV**

Before attempting to connect, operate or adjust this product, please read these instructions thoroughly.

Spanish Quick Use Guide is included.

Guía para rápida consulta en español está incluida.

For assistance, please call: 1-800-311-PANA(7262) or send e-mail to: consumerproducts@panasonic.com

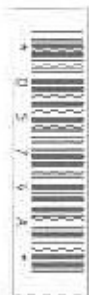

L8QT0574A

Things You Should Know

Thank you for choosing Panasonic!

You have purchased one of the most sophisticated and reliable products on the market today. Used properly, we're sure it will bring you and your family years of enjoyment. Please take time to fill in the information below. The serial number is on the tag located on the underside of your Palmcorder. Be sure to **retain this manual** as your convenient Palmcorder information source.

Date of Purchase

Dealer Purchased From

Dealer Address

Dealer Phone No.

Model No.





Serial No.

Safety Precautions

WARNING: TO PREVENT FIRE OR SHOCK HAZARD, DO NOT EXPOSE THIS EQUIPMENT TO RAIN OR MOISTURE.

Your Mini DV Palmcorder is designed to record and play back in Standard Play (SP) mode and Long (LP) mode.

It is recommended that only cassette tapes that have been tested and inspected for use in VCR machines with the Mini DV mark be used.

 CAUTION RISK OF ELECTRIC SHOCK DO NOT OPEN		 <p>This symbol warns the user that uninsulated voltage within the unit may have sufficient magnitude to cause electric shock. Therefore, it is dangerous to make any kind of contact with any inside part of this unit.</p>
CAUTION: TO REDUCE THE RISK OF ELECTRIC SHOCK, DO NOT REMOVE COVER (OR BACK) NO USER-SERVICEABLE PARTS INSIDE REFER SERVICING TO QUALIFIED SERVICE PERSONNEL	 <p>This symbol alerts the user that important literature concerning the operation and maintenance of this unit has been included. Therefore, it should be read carefully in order to avoid any problems.</p>	

The above markings are located on the appliance bottom cover.

Declaration of Conformity

Model Number : **PV-DV102**
Trade Name : **Panasonic**
Responsibility Party : **Matsushita Electric Corporation of America**
Address : **One Panasonic Way Secaucus New Jersey 07094**
Telephone Number : **1-800-211-PANA(7262)**

This device complies with Part 15 of the FCC Rules. Operation is subject to the following two conditions: (1) This device may not cause harmful interference, and (2) this device must accept any interference received, including interference that may cause undesired operation.

Note: This equipment has been tested and found to comply with Part 15 of the FCC Rules. These limits are designed to provide reasonable protection against harmful interference when operated in a residential environment.

If this equipment does cause interference to radio or television reception, which can be determined by turning the equipment off and on, use the equipment in another location and/or utilize an electrical outlet different from that used by the receiver.

If necessary, consult the dealer or an experienced radio/TV technician for help. You may find the booklet, 'Something About Interference' available from FCC local regional offices helpful.

FCC Warning: To assure continued FCC compliance, use only the provided shielded interface cable when connecting digital video camcorder to computer in accordance with instruction herein. Also, any unauthorized changes or modifications to this equipment would void the user's authority to operate.

Important Safeguards

Before Use

1. **Read Instructions** — All the safety and operating instructions should be read before the unit is operated.
2. **Retain Instructions** — The safety and operating instructions should be retained for future reference.
3. **Heed Warnings** — All warnings on the unit and in the operating instructions should be adhered to.
4. **Follow Instructions** — All operating and maintenance instructions should be followed.
5. **Cleaning** — Unplug this video unit from the wall outlet before cleaning. Do not use liquid or aerosol cleaners. Use a dry cloth for cleaning.
6. **Attachments** — Do not use attachments not recommended by the video product manufacturer as they may be hazardous.
7. **Water and Moisture** — Do not use this video unit near water — for example near a bath tub, wash bowl, kitchen sink, or laundry tub, in a wet basement, or near a swimming pool, and the like.
8. **Accessories** — Do not place this video unit on an unstable cart, stand, tripod, bracket, or table. The video unit may fall, causing serious injury to a child or adult, and serious damage to the unit. Use only with a cart, stand, tripod, bracket, or table recommended by the manufacturer, or sold with the video unit. Any mounting of the unit should follow the manufacturer's instructions and should use a mounting accessory recommended by the manufacturer. An appliance and cart combination should be moved with care. Quick stops, excessive force, and uneven surfaces may cause the appliance and cart combination to overturn.
9. **Ventilation** — Slots and openings in the cabinet are provided for ventilation and to ensure reliable operation of the video unit and to protect it from overheating. These openings must not be blocked or covered. Never place the video unit on a bed, sofa, rug, or other similar surface, or near or over a radiator or heat register. This video unit should not be placed in a built-in installation such as a bookcase or rack unless proper ventilation is provided or the manufacturer's instructions have been adhered to.
10. **Power Sources** — This video unit should be operated only from the type of power source indicated on the marking label. If you are not sure of the type of power supply to your home, consult your appliance dealer or local power company. For video units intended to be operated from battery power, or other sources, refer to the operating instructions.



11. **Grounding or Polarization** — This video unit may be equipped with either a polarized 2-wire AC (Alternating Current) line plug (a plug having one blade wider than the other) or 3-wire grounding type plug, a plug having a third (grounding) pin. The 2-wire polarized plug will fit into the power outlet only one way. This is a safety feature. If you are unable to insert the plug fully into the outlet, try reversing the plug. If the plug still fails to fit, contact your electrician to replace your obsolete outlet. Do not defeat the safety purpose of the polarized plug. The 3-wire grounding type plug will fit into a grounding type power outlet. This is a safety feature. If you are unable to insert the plug into the outlet, contact your electrician to replace your obsolete outlet. Do not defeat the safety purpose of the grounding type plug.
12. **Power-Cord Protection** — Power-supply cords should be routed so that they are not likely to be walked on or pinched by items placed upon or against them, paying particular attention to cords of plugs, convenience receptacles, and the point where they exit from the unit.
13. **Outdoor Antenna Grounding** — If an outside antenna or cable system is connected to the video unit, be sure the antenna or cable system is grounded so as to provide some protection against voltage surges and built-up static charges. Part 1 of the Canadian Electrical Code, in USA Section 810 of the National Electrical Code, provides information with respect to proper grounding of the mast and supporting structure, grounding of the lead-in wire to an antenna discharge unit, size of grounding conductors, location of antenna discharge unit, connection to grounding electrodes, and requirements for the grounding electrode.

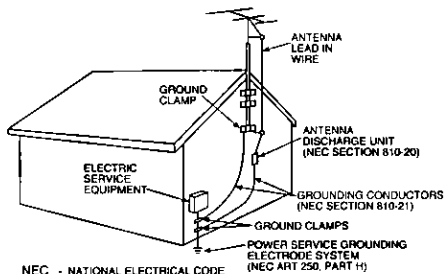

14. **Lightning** — For added protection of this video unit receiver during a lightning storm, or when it is left unattended and unused for long periods of time, unplug it from the wall outlet and disconnect the antenna or cable system. This will prevent damage to the video unit due to lightning and power-line surges.

Important Safeguards

15. **Power Lines** — An outside antenna system should not be located in the vicinity of overhead power lines or other electric light or power circuits, or where it can fall into such power lines or circuits. When installing an outside antenna system, extreme care should be taken to keep from touching such power lines or circuits as contact with them might be fatal.
16. **Overloading** — Do not overload wall outlets and extension cords as this can result in a risk of fire or electric shock.
17. **Objects and Liquids** — Never push objects of any kind into this video unit through openings as they may touch dangerous voltage points or short out parts that could result in a fire or electric shock. Never spill liquid of any kind onto the video unit.
18. **Servicing** — Do not attempt to service this video unit yourself as opening or removing covers may expose you to dangerous voltage or other hazards. Refer all servicing to qualified service personnel.
19. **Damage Requiring Service** — Unplug this video unit from the wall outlet and refer servicing to qualified service personnel under the following conditions:
 - a. When the power-supply cord or plug is damaged.
 - b. If any liquid has been spilled into, or objects have fallen onto, the video unit.
 - c. If the video unit has been exposed to rain or water.
 - d. If the video unit does not operate normally by following the operating instructions. Adjust only those controls that are covered by the operating instructions, as an improper adjustment of other controls may result in damage and will often require extensive work by a qualified technician to restore the video unit to its normal operation.
 - e. If the video unit has been dropped or the cabinet has been damaged.
 - f. When the video unit exhibits a distinct change in performance — this indicates a need for service.
20. **Replacement Parts** — When replacement parts are required, be sure the service technician has used replacement parts specified by the manufacturer or have the same characteristics as the original part. Unauthorized substitutions may result in fire, electric shock or other hazards.
21. **Safety Check**— Upon completion of any service or repairs to this video unit, ask the service technician to perform safety checks to determine that the video unit is in safe operating order.

Precautions

USE & LOCATION

- **TO AVOID SHOCK HAZARD ...** Your Palmcorder and power supply should not be exposed to rain or moisture. Do not connect the power supply or operate your Palmcorder if it gets wet. Your Palmcorder has been designed for outdoor use, however it is not designed to sustain direct exposure to water, rain, sleet, snow, sand, dust, or direct splashing from a pool or even a cup of coffee. This action could permanently damage the internal parts of your Palmcorder. Do not attempt to disassemble this unit. There are no user serviceable parts inside. Unplug your Palmcorder from the power supply before cleaning.
- **DO NOT AIM YOUR PALMCORDER AT THE SUN OR OTHER BRIGHT OBJECTS**
- **DO NOT LEAVE THE PALMCORDER WITH THE EVF AIMED DIRECTLY AT THE SUN AS THIS MAY CAUSE DAMAGE TO THE INTERNAL PARTS OF THE EVF**
- **DO NOT EXPOSE YOUR PALMCORDER TO EXTENDED HIGH TEMPERATURE ...** Such as, direct sunlight, inside a closed car, next to a heater, etc... This action could permanently damage the internal parts of your Palmcorder.
- **AVOID SUDDEN CHANGES IN TEMPERATURE ...** If the unit is suddenly moved from a cold place to a warm place, moisture may form on the tape and inside the unit.
- **DO NOT LEAVE YOUR PALMCORDER OR THE POWER SUPPLY TURNED ON WHEN NOT IN USE.**
- **STORAGE OF YOUR PALMCORDER ...** Store and handle your Palmcorder in a manner that will not subject it to unnecessary movement (avoid shaking and striking). Your Palmcorder contains a sensitive pick-up device which could be damaged by improper handling or storage.

CARE

- **TO CLEAN YOUR PALMCORDER ...** Do not use strong or abrasive detergents when cleaning your Palmcorder body.
- **TO PROTECT THE LENS ...** Do not touch the surface of the lens with your hand. Use a commercial Palmcorder lens solution and lens paper when cleaning the lens. Improper cleaning can scratch the lens coating.
- **TO PROTECT THE FINISH OF YOUR PALMCORDER ...** Before handling your Palmcorder, make sure your hands and face are free from any chemical products, such as suntan lotion, as it may damage the finish.

Table of Contents

Things You Should Know	2
Important Safeguards	3
Precautions	4
Before Using	6
• Easy Cassette Eject	7
Quick Guide	10
Supplying Power	13
Setting the Clock	15
Using the Palmcorder Menu	16

Before Use

Camera Recording	17
• Simple Recording	17
• Digital PhotoShot™ Mode	19
• Zoom	20
Special Effect Features	22
Advanced Settings	27

Camera

Playback Your Recordings	31
Special Effect Features	33

VCR

Digital Features	39
Editing Features	43
Card (Optional) Features	47
W/ PC Connection	
• Transferring Your Images (Windows)	54
• PHOTOVU/MPEG4 Movie Messenger™ System	57
• Transferring Your Images (i.LINK) (Windows)	69
• PHOTOVU/MPEG4 Movie Messenger™ System (i.LINK)	70
• Palmcorder USB Device Driver/SD Drive	72
• Palmcorder File Converter	75
• Web Camera (For Windows XP users/For Windows 98SE, Me, 2000 users)	77
• Warning Indications	86
W/ Mac PC Connection	
• Transferring Your Images (Macintosh)	87

Special Features

Palmcorder Accessory System	89
Palmcorder Accessory Order Form	90
Notes On Operations	91
Specifications	93
Before Requesting Service	94
On-Screen Display (OSD)	96
Request for Service Notice	97
Limited Warranty	98
Servicenter List	99
Spanish Quick Use Guide/Guía Para Uso Rápido	100
MENU OSD	104
Electronic Viewfinder/LCD Monitor Indications	108
Index of Controls	112
Index	115

For Your Information

Before Using

Unpack your Palmcorder

1 pc. AC Adaptor (PV-DAC11) with AC Cable and DC Cable



1 pc. USB Cable (K1HA05CD0001)



1 pc. Shoulder Strap (LSFC0016)



1 pc. Audio Adaptor (LSJP0829)



1 pc. CD-ROM of Driver Software for Windows 98SE/Me/2000/XP and Macintosh; USB Device Driver for Windows 98SE/Me/2000/XP; PHOTOVU/MPEG4 Movie Messenger™ System for Windows 98SE/Me/2000/XP; Built-in SD Drive for Macintosh (LSFT0491)



1 pc. Battery Pack (CGR-D08/CGR-D08R)



1 pc. A/V Cable (LSJA0280)



1 pc. Lens Cap (LSYF0518) with Lens Cap Strap (LSGQ0066)



Microsoft®, Windows® and Windows Media are registered trademarks of Microsoft in the United States and other countries.

Macintosh, iMac, iBook, PowerBook, Power Macintosh, Power Mac, and Mac are trademarks or registered trademarks of Apple Computer, Inc.

Intel® Pentium® is a registered trademark.

i.LINK is a trademark.

PHOTOVU/MPEG4 Movie Messenger™ System is a registered trademark.

IBM is a registered trademark of IBM Company.

MultiMediaCard is a registered trademark.

SD is a trademark.

How to remove the Sensor tag

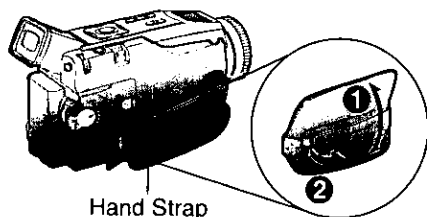

1 Open the Hand Strap as illustrated at left.

2 Remove the Sensor tag. Then, replace the Hand Strap.

Record Speed/Playback Time

Use only those tapes having the ^{Mini} DV logo indicating the 6.35 mm digital standard.

Cassette type	Record Speed/Playback time	
	SP	LP
AY-DVM30EA	30 minutes	45 minutes
AY-DVM60EA	60 minutes	90 minutes
AY-DVM80EA	80 minutes	120 minutes

Erase Protection

Cassettes have a sliding record tab to ensure recordings are not accidentally erased.

1 To prevent accidental erasure: Slide the tab to the left (open).

2 To record again: Slide the tab to the right (close).

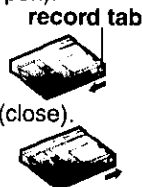

Easy Cassette Eject/Insertion

- If the Palmcorder is connected to a power source, the cassette can be inserted and ejected without turning the Palmcorder on.

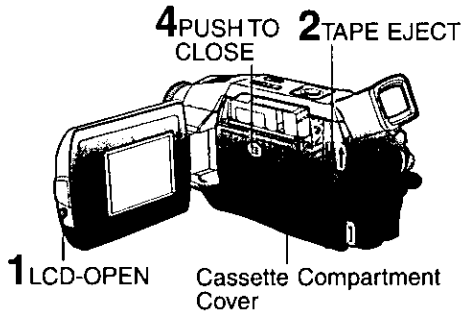

Before you begin

- Connect the Palmcorder to a power source. (pp. 13, 14)

- 1 Press **LCD-OPEN** to unlock the LCD monitor, and **swing it fully open**.
 - 2 Slide **TAPE EJECT** to open the Cassette Compartment Cover.
 - 3 Insert a cassette record tab up, window side facing out.
 - 4 Press **PUSH TO CLOSE** to close the Cassette Compartment Cover.
- **To remove the cassette...**
Slide **TAPE EJECT** to open the Cassette Compartment Cover and pull the cassette tape straight out.

Note

- When inserting the cassette, make sure it is facing the right direction and then push it in completely.

Attaching the Shoulder Strap

- 1 Undo the two strap ends from their buckles.
 - 2 Thread the strap ends through the Strap Attachment Rings.
 - 3 Reinsert the strap ends through their buckles.
 - Make sure the straps are not twisted.
-

Adjust the Length

- 1 Loosen the strap from the Buckle and create a loop.
- 2 Pull the strap firmly through the Buckle to shorten or lengthen the strap.

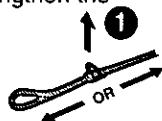

Hand Strap

Adjust the length of the Hand Strap to the size of your hand as illustrated.

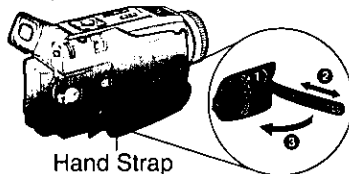

Lens Cap

Attaching the Lens Cap Strap:

Thread the Lens Cap Strap through the Strap Attachment Ring as shown.

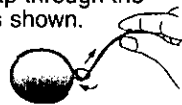

Attaching the Lens Cap Cord to the Hand Strap:

Remove the Hand Strap from the front clasp and thread the Strap through the loop in the Lens Cap Cord.

Reattach the Hand Strap.



Before Using

Using the Built-in Light

To brighten the natural colors in a scene.

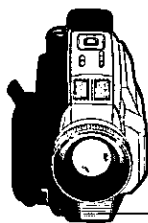

Built-in Light

Note

- Using Light reduces battery time.
- Provide adequate ventilation if using Light in a hot environment for a long time.
- Set LIGHT to OFF when not in use.
- When replacing the bulb, see page 91.

Remote Control (Optional)

You can operate the major functions of your Palmcorder from up to approximately 5 m (16 feet) away (indoors). Aim the IR Remote Control toward the front of the Palmcorder and press the desired buttons (Remote Sensor is located under the lens).

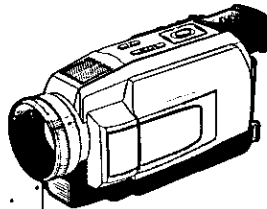

Remote Sensor

Controlled Functions

- Rec/Pause (p. 17)
- Tele (Zoom) (p. 20)
- Wide (Zoom) (p. 20)
- Date/Time (p. 108)
- Reset (p. 44)
- PhotoShot (p. 19)
- Display On TV (p. 38)
- Counter/Time Code (p. 109)
- Audio Dubbing (p. 43)
- Record (p. 46)
- Menu (p. 16)
- Play (p. 31)
- FF/Search (p. 33)
- REW/Search (p. 33)
- Pause/Select (pp. 15, 16, 35)
- Stop/Set (pp. 15, 16, 31, 46)
- Slow/Frame Advance (Forward) (pp. 34, 35)
- Slow/Frame Advance (Backward) (pp. 34, 35)
- Index Search (Forward) (pp. 35, 36)
- Index Search (Backward) (pp. 35, 36)
- Speaker Volume (p. 32)

Before you begin

- Connect the Palmcorder to a power source. (pp. 13, 14)
- Set POWER to CAMERA or M-CARD.

- 1** Hold down LIGHT for more than 0.7 seconds to turn ON or OFF.
 - "LD" will appear on the screen.

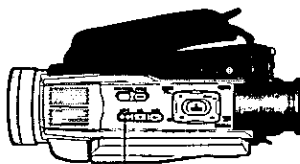

1 LIGHT

Caution

This light becomes hot during operation. Make sure nothing covers the light during operation.

To operate Camera functions:

Set POWER to CAMERA.

To operate VCR functions:

Set POWER to VCR.

Replace the Battery

Optional

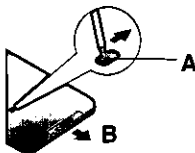

1 Insert a slender pointed object, such as the tip of a ball-point pen into the slot so that it fits into the hole (as shown A). Then, while sliding to the right, pull the Battery Tray out with your fingernail.



2 Insert the battery into the Battery Tray with the ⊕ mark facing down.
Do not reverse the polarity.



3 Insert the Battery Tray.

Replace battery with Panasonic PART NO. VSBW0004 (CR2025) only. Use of another battery may present a risk of fire or explosion.

Caution: battery may explode if mistreated. Dispose of used battery properly. Keep away from children. Do not recharge, disassemble or dispose of in a fire.

Remote Controlling Two Palmcorders

You can control any two Panasonic Palmcorders with one Remote control (Optional). In order for the remote to distinguish between the two units, it is necessary to set one of the Palmcorders to VCR 2. On the remote, press VCR 1 or VCR 2 to control the desired Palmcorder.

Optional

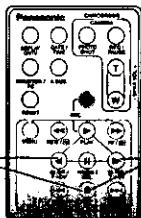

For VCR 2: Press these buttons at the same time.

For VCR 1: Press these buttons at the same time.

Note

• When the Palmcorder and remote are not set to the same mode (VCR1 or VCR2), "CHECK REMOTE MODE (REMOTE)" will appear.



- 1** Set **POWER** to **VCR** or **CAMERA**.
 - The **POWER** Lamp lights red.
 - Be sure **POWER** is fully turned to **VCR** or **CAMERA** position.
- 2** Press **MENU** to display the **VCR** or **CAMERA** mode menu screen.
- 3** Rotate **JOG KEY** to select **SET-UP** in the **CAMERA** mode menu screen or **PLAY MODE** in the **VCR** mode menu screen, then press **JOG KEY** to display the **CAMERA SET-UP** or **VCR PLAY MODE** menu screen.
- 4** Rotate **JOG KEY** to select **REMOTE**, and then press **JOG KEY** to select **VCR 2**. (Menu OSD: pp. 105, 106). Leave the other Palmcorder set to **VCR 1**.
- 5** Set the **Remote Control (Optional)** to **VCR 1** or **VCR 2** to correspond with the Palmcorder you wish to control. (See above left.)

• After replacing the Remote Control Battery, the remote will default to **VCR 1**.

Quick Guide

Insert the Battery Pack

Before you begin

- Charge the Battery. (p. 13)

Protection Film

Note

- Remove the Protection Film before use.

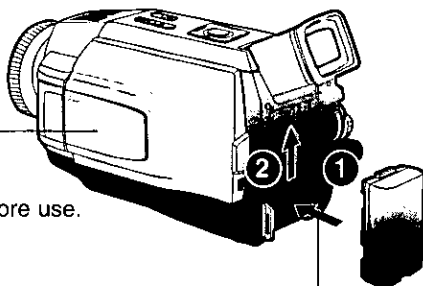

- 1** Insert the Battery Pack and slide it up until it locks with a click.

Insert Cassette

These Palmcoders are equipped with the Easy Cassette Eject System so it is easy to insert or remove tapes, even when on a tripod. (p. 7)

- 1** Press LCD-OPEN to unlock the LCD monitor, and swing it fully open.

- 2** Set POWER to VCR or CAMERA.

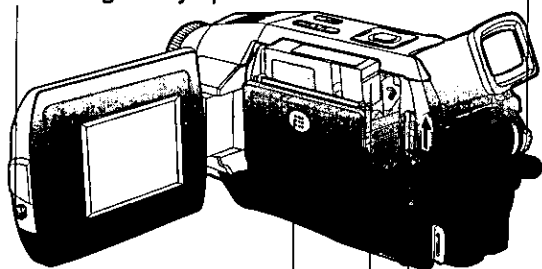

- 3** Slide TAPE EJECT to open the Cassette Compartment Cover.

- 4** Insert a cassette record tab up, window side facing out.
 - Make sure the record tab is closed. (p. 6)

- 5** Press PUSH TO CLOSE mark to close the Cassette Compartment Cover.

Camera Recording

When the LCD monitor is fully open, the Viewfinder automatically turns OFF.

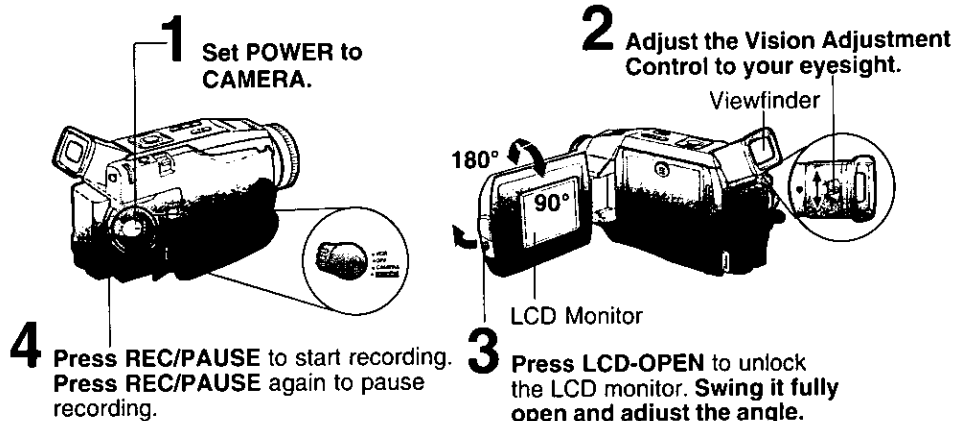
- 1** Set POWER to CAMERA.
 - 2** Adjust the Vision Adjustment Control to your eyesight.
 - 3** Press LCD-OPEN to unlock the LCD monitor. Swing it fully open and adjust the angle.
 - 4** Press REC/PAUSE to start recording. Press REC/PAUSE again to pause recording.
- 
- Labels: Viewfinder, LCD Monitor

To Watch Playback in the LCD (Liquid Crystal Display)

When the LCD monitor is fully open, the Viewfinder automatically turns OFF.

Before you begin

- Charge the Battery. (p. 13)

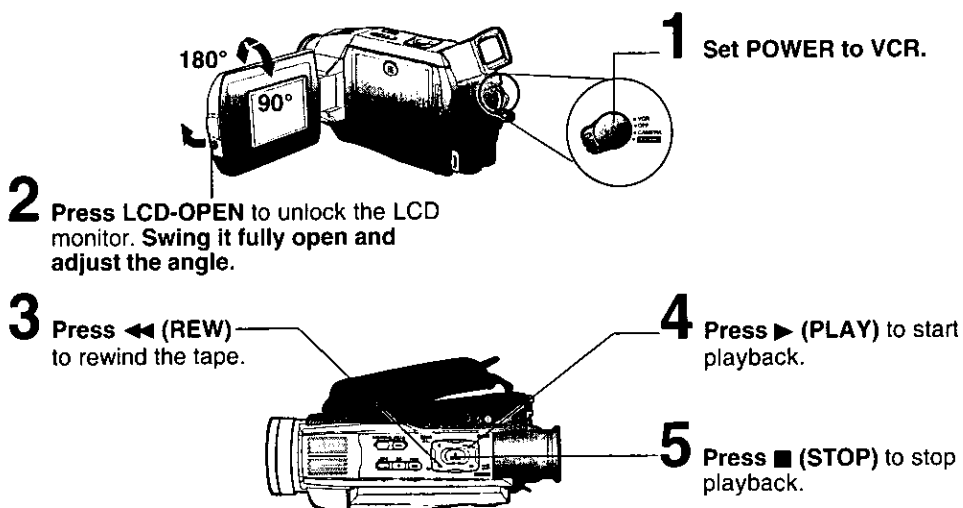
- 1** Set POWER to VCR.
 - 2** Press LCD-OPEN to unlock the LCD monitor. Swing it fully open and adjust the angle.
 - 3** Press ◀ (REW) to rewind the tape.
 - 4** Press ▶ (PLAY) to start playback.
 - 5** Press ■ (STOP) to stop playback.
- 
- Labels: LCD Monitor

Quick Guide

Insert Memory Card (Optional)*

Before you begin

- Charge the Battery. (p. 13)

*Memory Card: MultiMediaCard or SD Memory Card (p. 91)

- Be sure to insert the Memory Card before using the Card PhotoShot. (p. 47)

Below is a list of memory cards which can be used in this Palmcorder.

Memory Card	Capacity
MultiMediaCard (SanDisk brand)	8 MB, 16 MB
SD Memory Card (optional) (p. 89)	16 MB, 32 MB, 64 MB

SD Memory Card write protection switch



A write protection switch is located on the SD Memory Card. Sliding the switch to the "LOCK" position prevents writing on or formatting the card.

↑ Write protection Switch

- 1** Set **POWER** to **OFF**.
- 2** Slide **DOOR OPEN** to open M-CARD door.
- 3** Insert the Memory Card and hold in place until you hear a click.
- 4** Close the M-CARD Door.

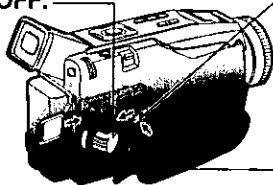

To remove the Memory Card...

Press here to eject the card. →



About the M-CARD Lock Switch

When inserting the Memory Card

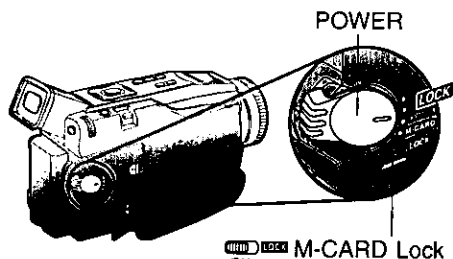

LOCK M-CARD Lock

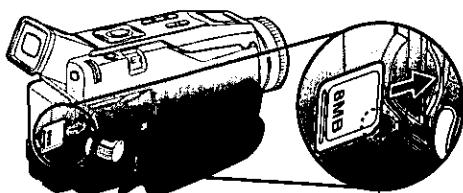

cropped corner

Note

- By sliding M-CARD Lock to LOCK, you can prevent POWER from accidentally entering the M-CARD position when changing POWER to CAMERA.

Note

- When inserting the Memory Card, insert with the cropped corner down as shown in the illustration above.

Charge the Battery Pack on the AC Adaptor

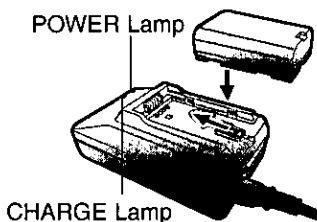
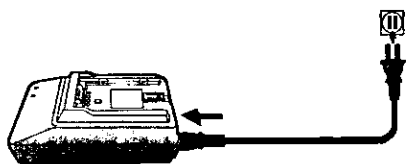

1 Connect and plug in the Power Cord as shown.

- POWER Lamp will light.
- Remove the DC Cable, if attached, from the adaptor.

2 Attach the Battery as shown to charge.

- CHARGE Lamp lights up. It goes out when charging is complete (approx. 1 hour). Expect approx. 1 hour 30 minutes of operation (EVF usage) when fully charged.

3 Remove the Battery. Slide the Battery out and then lift up.

Note

About the Flashing of the CHARGE Lamp

- Charge the Battery within an ambient temperature range of 10 °C (50 °F) and 30 °C (86 °F).
- If charging is done in extreme low or high temperatures, Battery charge time increases.

CHARGE Lamp flashes when...

- The Battery is being charged, but charging is taking longer than normal.
- Charging is not possible. Remove the Battery once, wait a short time, then re-attach it for charging.

Insert the Battery Pack

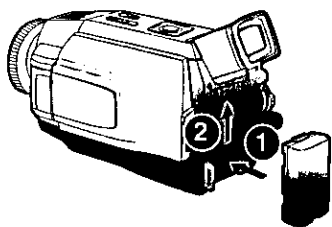

1 Insert the Battery Pack and slide it up until it locks with a click.

Remove the Battery Pack

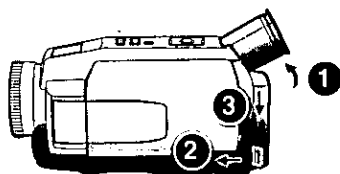

1 Tilt Viewfinder upward.

2 Remove the Battery Pack and slide the Battery downward while sliding the BATT RELEASE.

Supplying Power

Battery Care

Caution:

- Charge only with specified charger.
- Charge the Battery within an ambient temperature range of 10 °C (50 °F) and 30 °C (86 °F).
- The Battery may be warm after charging or just after use. This is normal.
- Do not use an insufficiently charged or worn out Battery.
- If charging is done in extreme low or high temperatures, Battery charge time increases.

Safety precautions:

- Do not place the Battery near, or dispose of in fire.
- Do not directly connect (short circuit) the positive (+) and negative (-) terminals.
- Never attempt to disassemble or reassemble the Battery.

To avoid damage to the Battery:

- Do not drop or jar the Battery.
- Use the Battery with specified models only.
- If the Battery is used in extremely high temperatures, a safety device will automatically prevent operation.

To insure longer battery life:

- **While not in use, remove Battery from the Palmcorder and AC Adaptor and store in a cool, dark, dry place.** If you leave the Battery in the Palmcorder or on the AC Adaptor, the Battery will no longer be rechargeable.
- Keep the Battery terminals clean.

U.S.A. CONSUMERS: ATTENTION:



A lithium ion/polymer battery that is recyclable powers the product you have purchased. Please call 1-800-8-BATTERY for information on how to recycle this battery.

Use AC Adaptor

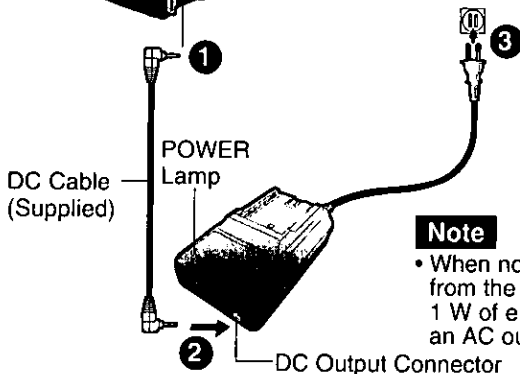
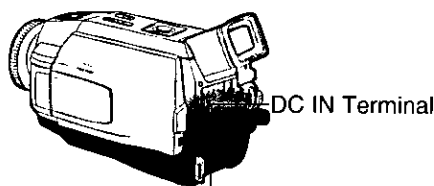
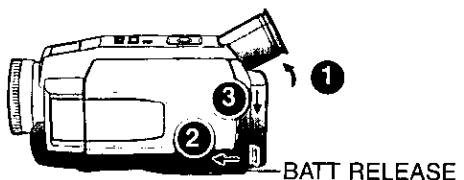

- 1 Slide the Battery downward while sliding BATT RELEASE to remove the Battery Pack. (p. 13)
- 2 Insert the DC Cable into the DC IN Terminal.
- 3 Connect the other end of the DC Cable to the AC Adaptor as shown.
- 4 Plug in the AC Adaptor.
 - The POWER Lamp on the AC Adaptor lights up.

Note

- When not in use, unplug the AC Adaptor from the AC outlet. (AC Adaptor consumes 1 W of electric power when plugged into an AC outlet even when not in use.)

Setting the Clock

Set the Date and Time

The date and time is calculated, including leap year, up to DEC 31 2089.

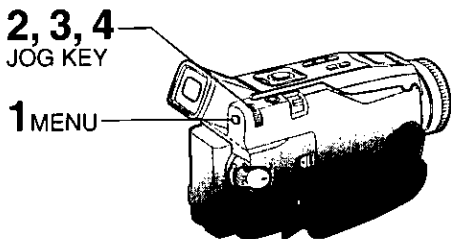

Before you begin

- Connect the Palmcorder to a power source. (pp. 13, 14)
- Set POWER to CAMERA or VCR.

- 1 Press **MENU** to display the Camera or VCR mode menu screen. (p. 16)

[CAMERA MENU] [VCR MENU]

```

CAMERA MENU
1:FUNCTION
2:ADJUST
3:REC MODE
4:SET-UP
5:DISPLAY SETTING
6:LCD/EVF SETTING
7:PHOTO TITLE
-SELECT:ROTATE JOG KEY
-SET :PUSH JOG KEY
-EXIT :PUSH MENU KEY
  
```

```

VCR MENU
1:PLAY FUNCTION
2:REC MODE
3:PLAY MODE
4:MULTI SETTING
5:DISPLAY SETTING
6:LCD/EVF SETTING
-SELECT:ROTATE JOG KEY
-SET :PUSH JOG KEY
-EXIT :PUSH MENU KEY
  
```

- 2 Rotate **JOG KEY** to select **DISPLAY SETTING**, and then press **JOG KEY** to display the DISPLAY SETTING menu screen.

- 3 Rotate **JOG KEY** to select **CLOCK-SET**, and then press **JOG KEY** to set to ON. (Menu OSD: pp. 105, 107.)
 - The DATE/TIME SETTING menu is displayed.

- 4 Rotate **JOG KEY** to select YEAR, then press **JOG KEY** to fix and move to the next item. Likewise, set the month, day, hour, and minutes.

EXAMPLE:

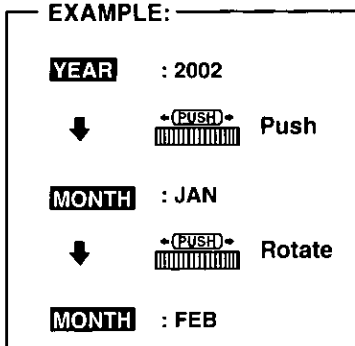

```

DATE/TIME SETTING
YEAR : 2002
MONTH : OCT
DAY : 15
HOUR : 8PM
MINUTE: 10
-SELECT:PUSH JOG KEY
-SET :ROTATE JOG KEY
-EXIT :PUSH MENU KEY
  
```

Note

- To make corrections, Press **JOG KEY** repeatedly to move back to an item and correct.
- A built-in Battery maintains clock operation. If the Palmcorder is not connected to a power source for a few months, the built-in battery may discharge and "CLOCK BATTERY" indication appears. (p. 96)

When DATE/TIME setting is completed, press **MENU** three times to start the clock and exit.

Using the Palmcorder Menu

The Palmcorder features three menu displays: one for CAMERA mode (recording), one for M-CARD (Memory Card Photo Mode) and one for VCR mode (Playback). (pp. 104~107)

- While the Menu screen is displayed, you cannot record on or play a tape.
- While recording, the Menu screen cannot be displayed.
- During playback, the Menu screen can be displayed.

Before you begin

- Connect the Palmcorder to a power source. (pp. 13, 14)
- Set POWER to CAMERA or VCR.

2, A, B, C
JOG KEY

1, D
MENU

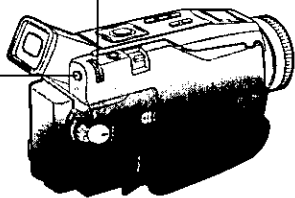

Displaying the MENU

- 1 Press MENU to display the CAMERA or VCR menu (according to the POWER setting).
- 2 Rotate JOG KEY to select a menu item.

Setting the MENU Items (EX. VCR Mode menu)

- A Press JOG KEY to set your selection.
- B Rotate JOG KEY to select a menu item.

VCR PLAY FUNCTION
DEFUNCTION
●OFF MIRROR STROBE
NOISE/C BLINK TRAIL
STRETCH
EFFECT
●OFF
SEP1A MONO
DZOOM ●OFF ON
SELECT: ROTATE JOG KEY
SET : PUSH JOG KEY
EXIT : PUSH MENU KEY

VCR REC MODE FUNCTION
●OFF MIRROR STROBE
NOISE/C BLINK TRAIL
STRETCH
INDEX
●OFF
SEP1A MONO
DZOOM ●OFF ON
SELECT: ROTATE JOG KEY
SET : PUSH JOG KEY
EXIT : PUSH MENU KEY

- C Press JOG KEY to set your selection.
 - The "●" mark indicates selection.
- D Press MENU twice to exit the menu.

CAMERA Main menu

- 1: **D. FUNCTION**
CAMERA FUNCTION menu is displayed. To select D.FUNCTION, D.ZOOM, or PROGRESSIVE.
- 2: **ADJUST**
CAMERA ADJUST menu is displayed. To select PROG. AE or CINEMA.
- 3: **REC MODE**
CAMERA REC-MODE menu is displayed. To select REC-SPEED, AUDIO-REC, INDEX, SHUTTER, SELF-REC, WIND-CUT, or ZOOM-MIC.
- 4: **SET-UP**
CAMERA SET-UP menu is displayed. To select REMOTE or BEEP.
- 5: **DISPLAY SETTING**
DISPLAY SETTING menu is displayed. To select DISPLAY, C.RESET, DATE/TIME, or CLOCK-SET.
- 6: **LCD/EVF SETTING**
LCD/EVF SETTING menu is displayed. To select LCD BRIGHTNESS, LCD COLOR or EVF BRIGHTNESS.
- 7: **PHOTO TITLE**
PHOTO TITLE menu is displayed. To select TITLE or MODE.

VCR Main menu

- 1: **PLAY FUNCTION**
VCR PLAY FUNCTION menu is displayed. To select D. FUNCTION, D.EFFECT, or D.ZOOM.
- 2: **REC MODE**
VCR REC MODE menu is displayed. To select REC-SPEED or AUDIO-DUB.
- 3: **PLAY MODE**
VCR PLAY MODE menu is displayed. To select INDEX, AUDIO, REMOTE, or B.SEARCH.
- 4: **MULTI SETTING**
MULTI SETTING menu is displayed. To select SPEED.
- 5: **DISPLAY SETTING**
DISPLAY SETTING menu is displayed. To select DISPLAY, C.RESET, DATE/TIME, or CLOCK-SET.
- 6: **LCD/EVF SETTING**
LCD/EVF SETTING menu is displayed. To select LCD BRIGHTNESS, LCD COLOR or EVF BRIGHTNESS.

Camera Recording

Simple Recording

Remove the lens cap and clip it to the hand strap.

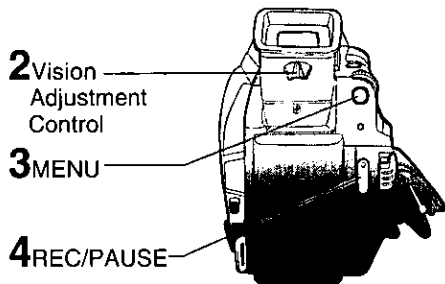
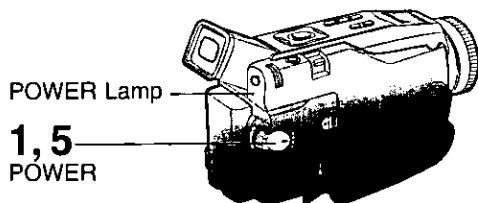
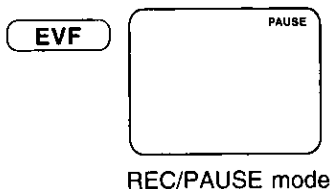
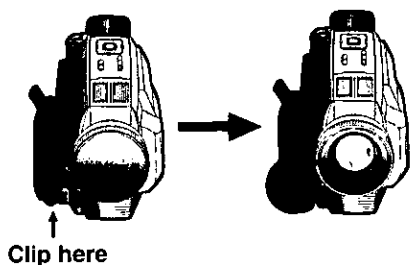

WARNING:

- Do not leave the Palmcorder with the EVF aimed directly at the sun as this may cause damage to the internal parts of the EVF.
- Do not lift, or carry, the Palmcorder by the EVF or the LCD Monitor.

Before you begin

- Connect the Palmcorder to a power source. (pp. 13, 14)
- Insert a cassette with the record tab closed. (p. 6)

- 1 Set POWER to CAMERA.**
 - The POWER Lamp lights red.
 - Be sure POWER is fully turned to the CAMERA position.
- 2 With the Viewfinder Eye Cup held up against your eye, adjust the Vision Adjustment Control to your eyesight.**
 - Adjust the EVF Brightness of the Viewfinder if necessary.
 - Please refer to "To adjust the LCD/ EVF BRIGHTNESS or COLOR" on page 18.
- 3 Set to REC-SPEED "SP" or "LP" in the CAMERA Mode Menu.**
(Menu OSD: p. 104)
- 4 Press REC/PAUSE to start recording.**
 - "REC" is displayed on the screen.
 - Press REC/PAUSE again to pause recording.
- 5 Set POWER to OFF when finished.**
 - To remove the cassette, slide TAPE EJECT.

- When the Palmcorder is aimed at excessively bright objects, or bright lights, a vertical bar may appear in the picture. This is a normal characteristic of the CCD pick-up device. Try to avoid this whenever possible.

To conserve power

After 5 minutes, the Record/Pause mode will automatically change to Standby mode.

To resume recording, set POWER to OFF and then ON again.

Camera Recording

Using the LCD Monitor

The LCD (Liquid Crystal Display) monitor can be used while recording.

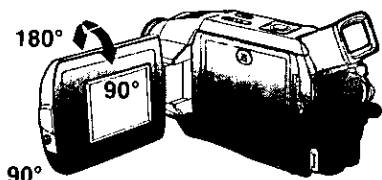
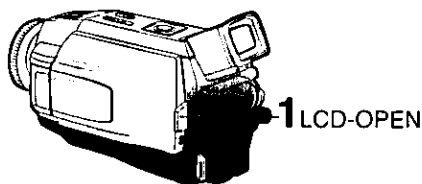

To adjust the LCD/EVF BRIGHTNESS or COLOR

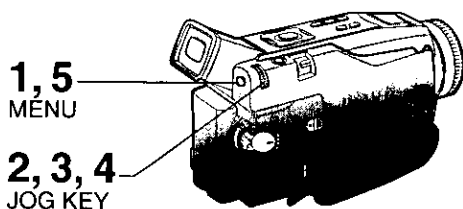

EVF/LCD

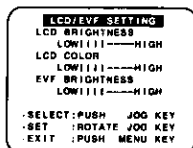

1 Press **LCD-OPEN** to unlock the LCD monitor.

2 Swing the LCD monitor fully open and adjust the viewing angle.

- The LCD monitor will automatically turn on.
- When the LCD monitor is completely closed, it will shut off automatically to save power.
- Adjust the LCD Brightness and/or color of the LCD monitor if necessary. Please refer to "To adjust the LCD/ EVF BRIGHTNESS or COLOR" below.

3 Start recording.

Note

- Using the LCD monitor will reduce battery operating time.
- Close the LCD monitor completely when not in use.

1 Press **MENU** to display the main menu screen.

2 Rotate **JOG KEY** to select **LCD/EVF SETTING** from the main menu screen. (Menu OSD: pp. 105, 107)

3 Press **JOG KEY** to display the LCD/ EVF SETTING screen.

4 Press **JOG KEY** to select LCD BRIGHTNESS, LCD COLOR, or EVF BRIGHTNESS, then rotate **JOG KEY** to adjust.

5 Press **MENU** twice to exit this mode.

Digital PhotoShot™ Mode

Use this feature to record a seven second (approx.) still image from the current camera picture. Audio is also recorded for on-the-spot narration. Or, you can add narration later with the Audio Dubbing feature to make an interesting slide show, etc. (p. 43)

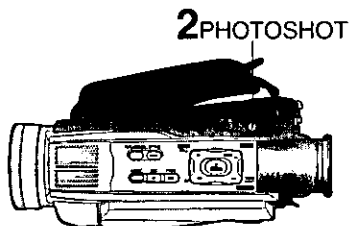
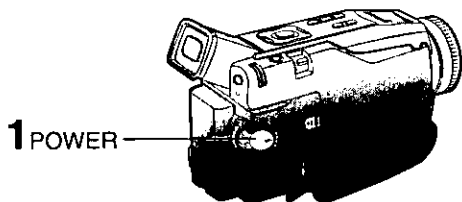

Progressive PhotoShot™ Mode

With the progressive PhotoShot Function, you can record still pictures with higher resolution than with the normal PhotoShot Function.

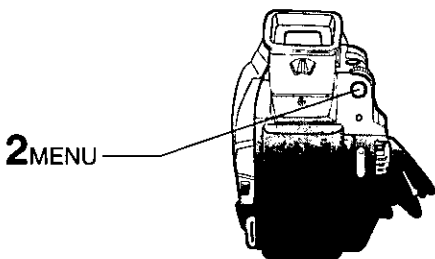
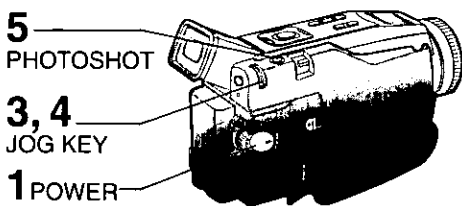

1 Set **POWER** to **CAMERA**.

2 Press **PHOTOSHOT** in Record/Pause mode. "PHOTO" will appear in the EVF or the LCD monitor.

EVF/LCD



Note

- If **SHUTTER** on the menu screen is set to **ON**, a sound effect similar to the shutter of a film camera will be heard when **PHOTOSHOT** is pressed.
- When **PHOTOSHOT** is pressed, the playback image takes approx. 7 seconds to process. After that, the Camera mode screen will be displayed.

Camera

1 Set **POWER** to **CAMERA**.

2 Press **MENU** to display the **CAMERA** mode menu screen.

3 Rotate **JOG KEY** to select **D.FUNCTION**, and press **JOG KEY** to display the **CAMERA FUNCTION** menu screen.

4 Rotate **JOG KEY** to select **PROGRESSIVE** and press **JOG KEY** to select **ON** or **OFF**.

- Press **MENU** twice to exit.
- "P" will appear in the EVF or the LCD monitor.

5 Press **PHOTOSHOT** in Record/Pause mode.

EVF/LCD



Note

- This Function may not work with some function settings.

Camera Recording

Zoom

You can gradually zoom in for close ups or zoom out for wide angle shots.

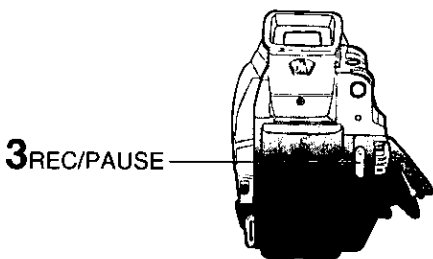
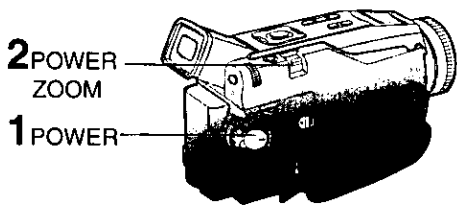

- 1 Set **POWER** to **CAMERA**.
- 2 **Zoom slowly:**
by lightly pressing the "T" (Telephoto) or the "W" (Wide Angle) side of the **POWER ZOOM**.

Zoom quickly:
by applying more pressure.

- 3 Start recording.

Note

- The zooming speed ranges from a slow 17 seconds to a fast 1.5 seconds according to the amount of pressure applied to the **POWER ZOOM**.

Zoom Microphone Function

Along with the zooming operation, the microphone's directional angle and sensitivity are varied for recording sounds.

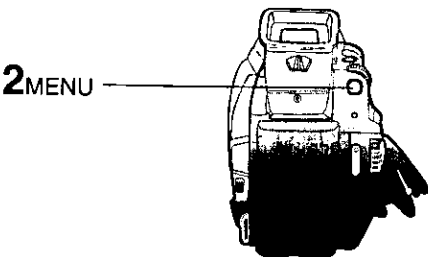
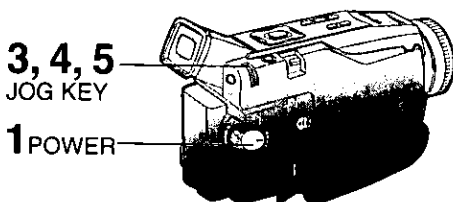

- 1 Set **POWER** to **CAMERA**.
- 2 Press **MENU** to display the **CAMERA** mode menu screen.
- 3 Rotate **JOG KEY** to select **REC MODE**, then press **JOG KEY** to display the **CAMERA REC-MODE** menu screen.
- 4 Rotate **JOG KEY** to select **ZOOM-MIC** in the **CAMERA REC-MODE** menu. (Menu OSD: p. 104)
- 5 Press **JOG KEY** to select **ON**.
 - Press **MENU** twice to exit.
 - "Z.MIC" will appear on the screen.

Note

- The Zoom Microphone Function may not work effectively if the surrounding noise is too loud.

Recording Check

To playback the final few seconds of the last recorded scene in the REC/PAUSE mode.

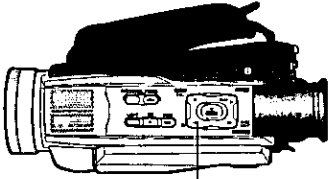

1 RECORDING CHECK ◀◀

- 1 Press **RECORDING CHECK** ◀◀ briefly in the REC/PAUSE mode.

The [CHK] indication appears. After checking, the Palmcorder returns to the REC/PAUSE mode.

- For Recording Check, the Palmcorder must be in the same mode (SP or LP) as was used for recording, otherwise the playback picture is distorted.

Recording Still Pictures

You can record still pictures of any desired duration together with sound.

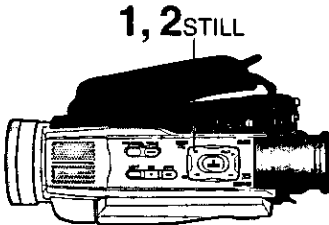

1, 2 STILL

- 1 While in RECORD mode, press **STILL** and hold for 2 seconds to capture a still picture. The captured still picture will be recorded together with sound.

- 2 Press **STILL** once again to release the still picture. The camera will resume recording real-time pictures.

Self Recording

Rotate the LCD monitor 180 degrees so it faces the same direction as the lens to record yourself.

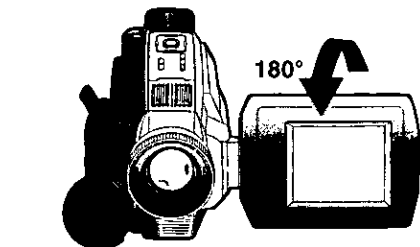
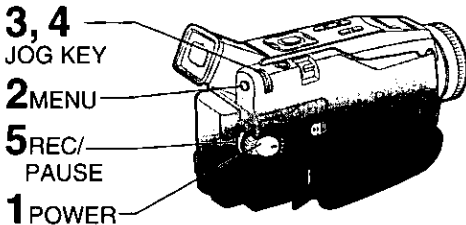

- 1 Set **POWER** to CAMERA.
- 2 Press **MENU** to display the CAMERA mode menu screen.

- 3 Rotate **JOG KEY** to select **REC MODE**, then press **JOG KEY** to display the CAMERA REC-MODE menu screen.

- 4 Rotate **JOG KEY** to select **SELF-REC**, and then press **JOG KEY** to select MIRROR.
 - The picture in the LCD monitor will appear reversed.

- 5 Start recording.

Special Effect Features

CINEMA Mode

You can record a picture compatible with a wide-screen TV equipped with an S2 picture terminal.

3, 4

JOG KEY

1 POWER

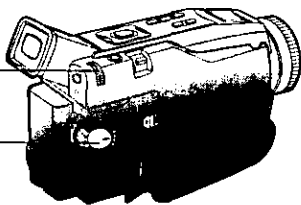

2 MENU

5 REC/PAUSE

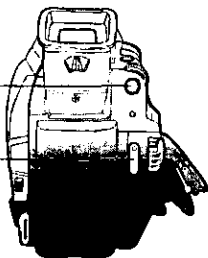

1 Set **POWER** to **CAMERA**.

2 Press **MENU** to display the **CAMERA** mode menu screen.

3 Rotate **JOG KEY** to select **ADJUST**, then press **JOG KEY** to display the **CAMERA ADJUST** menu screen.

4 Rotate **JOG KEY** to select **CINEMA**, and then press **JOG KEY** to select **ON**.

- A black strip will appear at the top and bottom of the picture.
- Press **MENU** twice to exit.
- "CINEMA" will appear on the screen.

5 Start recording.

EVF/LCD



Backlight

Use when recording a subject that is darker than the surrounding scene, is in a shadowed area, or when the light source is in back of your subject.

1 POWER

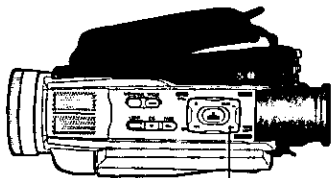
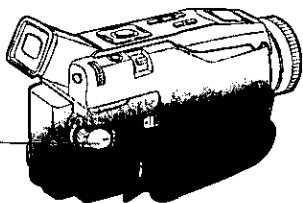

2, 3 **BACK LIGHT**

1 Set **POWER** to **CAMERA**.

2 Press **BACK LIGHT** to activate the Backlight feature.
• The Indicator "●" will appear in the EVF or LCD monitor.

3 Press **BACK LIGHT** again to cancel the Backlight feature.

EVF/LCD

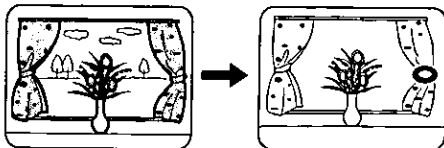

Note

- The Indicator "●" will not appear in the EVF or LCD monitor when **OFF** is selected in the **DISPLAY** menu.

Special Effect Features

Program AE

The Auto Exposure feature can be used to make quality recordings in a variety of scene situations.

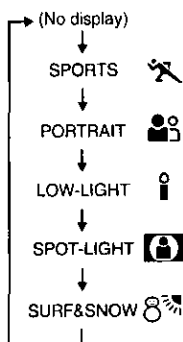
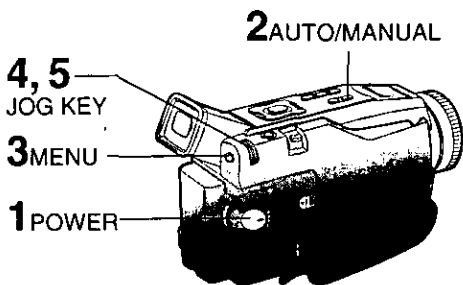

Note

SPORTS mode

- The recorded images will not be so blurred when they are viewed later using slow or still picture playback.
- When playing back a sports mode recording, the movement may appear slightly jerky.
- Do not use this mode when recording under fluorescent, mercury, or sodium lighting. These types of lights will affect the color and brightness of the images.
- A vertical band of light might appear when recording objects that are brightly illuminated or highly reflective.
- If the amount of light is insufficient, the SPORTS "A" indicator will flash in the EVF or the LCD monitor.
- The image may flicker if this mode is used indoors.

- 1 Set POWER to CAMERA.
- 2 Hold down AUTO/MANUAL for more than 0.7 seconds so that the "MNL" indication appears in the EVF or the LCD monitor.
- 3 Press MENU to display the menu screen.
- 4 Rotate JOG KEY to select ADJUST, and then press JOG KEY to display the CAMERA ADJUST menu screen.
- 5 Rotate JOG KEY to select PROG.AE, then press JOG KEY repeatedly to select one of the five modes shown below.
- 6 Repeat steps 2-5 to select OFF to cancel this feature.

Camera

Mode	Indication
	For recording fast action scenes.
	For recording only subjects in the foreground, while ignoring subjects in the background.
	For recording in extreme low light conditions.
	Recording in situations where subjects are under a spotlight(s).
	For recording in locations with a high degree of "Dazzle," such as snow slopes and the seashore.

PORTRAIT mode

- The image may flicker if this mode is used indoors.

LOW-LIGHT mode

- Scenes recorded in extremely low light levels may not come out properly.

SPOT-LIGHT mode

- If the recorded subject is extremely bright, the picture may appear whitish.

SURF&SNOW mode

- If the recorded subject is extremely bright, the picture may appear whitish.
- It is not possible to select the SPORTS mode or PORTRAIT mode together with the MagicPix mode in the Digital function camera menu.

Special Effect Features

Audio/Video Fade In/Out

You can make smoother scene transitions for a more professional look.

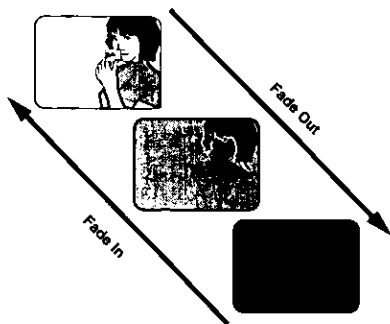
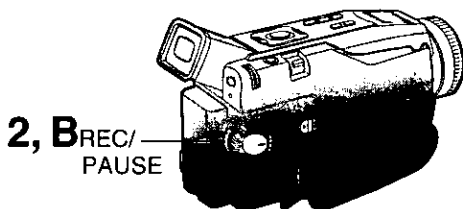
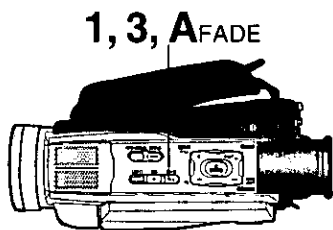

Fade In

Starting the first scene with "fade in" is very effective.

- 1** In REC/PAUSE mode, hold down **FADE** until the picture fades out.
- 2** Press **REC/PAUSE** to start recording.
- 3** Release **FADE** and the picture will gradually fade in.

Fade Out

Use to create a soft ending or (together with fade in) for a soft transition from one scene to the next.

- A** During recording, hold down **FADE** until the picture fades out.
- B** Press **REC/PAUSE** to pause the recording.

Special Effect Features

Picture in Picture (PinP)

You can display a PinP (still image) screen on the Main Picture.

Note

- PinP position is fixed at the bottom right of the screen.

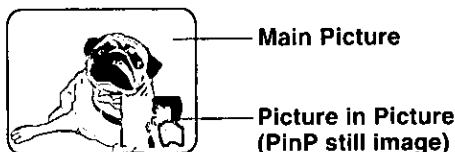

PHOTOSHOT

3, 4 JOG KEY

1 POWER

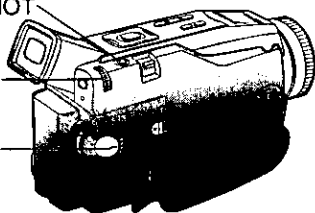

2 MENU

7 REC/PAUSE

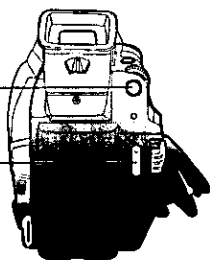

5, 6, 7
CAMERA STILL

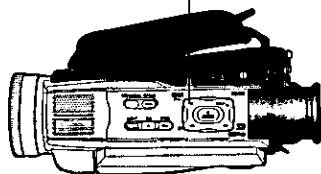

- 1 Set **POWER** to **CAMERA**.
- 2 Press **MENU** to display the menu screen.
- 3 Rotate **JOG KEY** repeatedly to select **D.FUNCTION**, then press **JOG KEY** to display the **CAMERA FUNCTION** menu screen.
- 4 Press **JOG KEY** to select **PinP**.
 - Press **MENU** twice to exit this menu.
 - "PinP" will appear in the EVF or the LCD monitor.
- 5 Aim at the scene you wish to place as PinP, then press **II (CAMERA STILL)** to freeze the image.
- 6 Press **II (CAMERA STILL)** again to place the frozen image as PinP.
- 7 Press **REC/PAUSE** to record a scene with PinP image.
 - Press **PHOTOSHOT** to record a scene with PinP image in PhotoShot mode.
 - Press **II (CAMERA STILL)** again to remove PinP image.

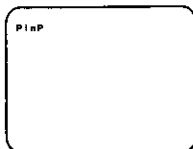

Special Effect Features

Photo Title

You can use PhotoShot images stored on a Memory Card to record a WIPE or MIX effect on a cassette.

Note

When Photo Title is set to ON, the selected image and Title will appear before each recording is made.

WIPE : The Photo title is replaced with the current scene in a wiping motion.



MIX : The photo title is replaced with the current scene in a gradual mixing effect.



Before you begin

- Connect the Palmcorder to a power source. (pp. 13, 14)
- Set POWER to OFF before inserting a recorded Memory Card. (pp. 47, 48)

- 1 Set POWER to CAMERA.
- 2 Press MENU to display the CAMERA menu screen. Then rotate and press JOG KEY to select **PHOTO TITLE**.
- 3 Rotate and press JOG KEY to select and set **MODE** and then **TITLE**.
1st : Select and set MODE (WIPE or MIX).
2nd : Select and set TITLE to "SET".

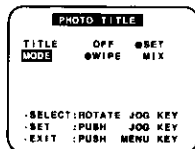

- "PLEASE WAIT" appears on-screen.
- The Multi image screen is displayed.

- 4 Rotate and press JOG KEY to select and set an image.
 - "PLEASE WAIT" is displayed while image is processed. Then, "PHOTO TITLE SET" is displayed for approx. 3 seconds, and the screen goes back to the Camera mode screen.
 - After Photo Title is performed, Digital Function turns off.
- 5 Press REC/PAUSE to start recording with Photo Title.
 - WIPE or MIX screen is displayed at the beginning of the recording. Then the Photo Title setting will be cleared automatically.

2, 3, 4

JOG KEY

1 POWER

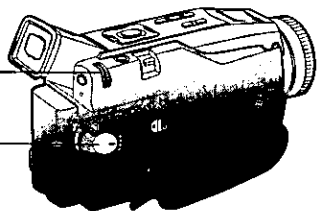

2 MENU

5 REC/
PAUSE

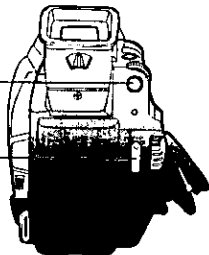

White Balance

Auto White Balance ("AWB") automatically maintains optimum color balance in most lighting conditions. However, when using Digital Functions, etc., you may get better results by using the manual adjustment.

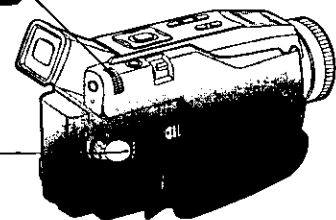

3, 4, A, B
JOG KEY

1 POWER

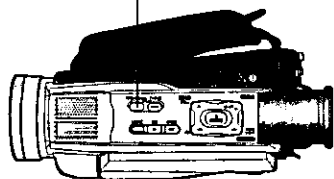

2 AUTO/MANUAL







Mode	Description
AWB	Automatically maintains optimum color balance in most lighting conditions.
	When the source illumination is a halogen lamp.
	When shooting outdoors on a sunny day.
* 	The White Balance setting that was previously set manually.

Note

- When ZOOM is set to 10X or higher, White Balance cannot be adjusted.

- 1** Set POWER to CAMERA.
- 2** Hold down AUTO/MANUAL for more than 0.7 seconds so that the "MNL" indication appears in the EVF or the LCD monitor.
- 3** Press JOG KEY repeatedly until "AWB" appears in the EVF or LCD monitor.
- 4** Rotate JOG KEY to select other modes. (See mode chart at left.)
 - Hold down AUTO/MANUAL for more than 0.7 seconds to cancel the setting.

* For manual White Balance adjustment:

- A.** Rotate JOG KEY to select "".
 - B.** Point the Palmcorder at a white object (full-screen) and hold JOG KEY down until "" indication stops flashing.
 - If "" indication flashes when the Palmcorder is turned on, the previous manual White Balance setting is in effect.
- In the following cases, the "" indication flashes:**
- The flashing indicates that the previously adjusted White Balance setting is still kept. This setting will be kept until White Balance is adjusted again.
 - Correct White Balance may not be attainable manually in poor lighting.

Advanced Settings

Auto Focus

The Palmcorder automatically adjusts the focus over the entire zoom range.

Manual Focus

Use Manual Focus (MF) when recording ...

- a subject through glass.
- a scene where the subject is far from the Palmcorder and there are objects in the foreground.
- a subject with distinct horizontal stripes.
- a subject not centered in the Viewfinder.
- subjects with shiny surfaces.
- an obliquely angled subject.
- a bright, flat subject such as a white wall.
- in low light situations.
- a scene with fast motions, like a golf swing.

Re-focusing may be required

- when your Palmcorder is aimed at a new scene.

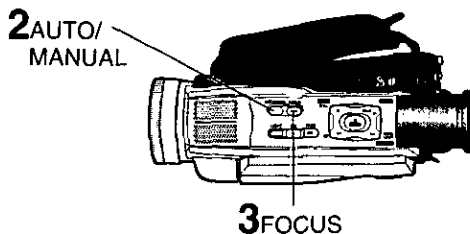
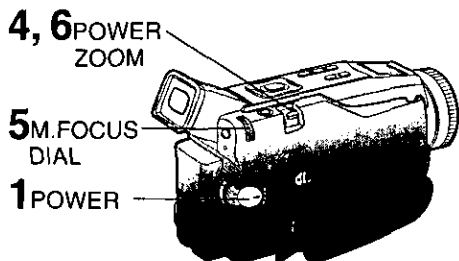

- 1 Set **POWER** to **CAMERA**.
- 2 Hold down **AUTO/MANUAL** for more than 0.7 seconds so that the "MNL" indication appears in the EVF or the LCD monitor.
- 3 Press **FOCUS** so that the "MF" (Manual Focus) indication appears in the EVF or the LCD monitor.
- 4 Press and hold **POWER ZOOM**, "T" side (Telephoto), until the lens is at maximum zoom in.
- 5 Turn **M.FOCUS DIAL** until the picture is in focus.
 - It may be necessary to back away from the subject to focus the image properly.
- 6 Press **POWER ZOOM** to "W" or "T" as desired.
 - The subject will remain in focus over the entire zooming range.
 - It may be necessary to back away from the subject to focus the image properly.

Note

- **DISPLAY** must be set to on for MF, AE, W.BALANCE, or BACK LIGHT to be displayed on the LCD or EVF.

Macro Focus (for close-ups)

Press the "W" side of **POWER ZOOM** to the maximum wide angle position.

Auto Focus will function with the subject as close as 25 mm (1 inch) in front of the lens.

High Speed Shutter

To record high speed motion (e.g. tennis stroke) with improved STILL or SLOW MOTION playback when watching the tape on this Palmcorder.

Auto Shutter

In the AUTO mode (no indication in the EVF and LCD monitor), the Palmcorder will automatically adjust the shutter speed (up to 1/350).

- AUTO mode is automatically selected whenever the POWER Switch is set to CAMERA.

Manual Selection

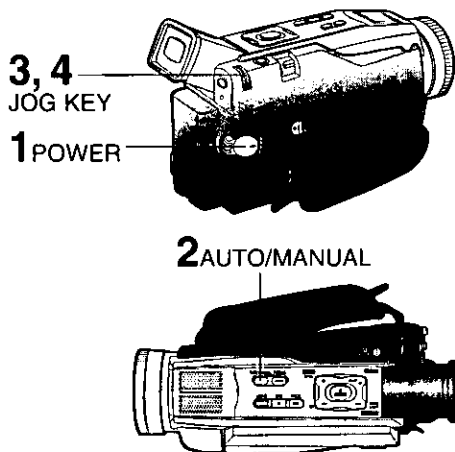

- 1 Set POWER to CAMERA.
- 2 Hold down AUTO/MANUAL for more than 0.7 seconds so that the "MNL" indication appears in the EVF or the LCD monitor.
- 3 Press JOG KEY repeatedly to display the shutter speed.
- 4 Rotate JOG KEY to choose one of the following shutter speeds.
 - Hold down AUTO/MANUAL for more than 0.7 seconds to cancel the setting.

EVF/LCD

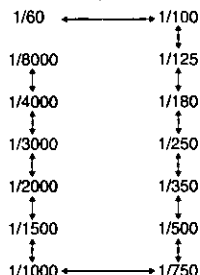
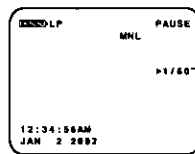

Note

- For proper color reproduction, it is recommended that you use this feature outdoors. For indoor High Speed Shutter recording, additional halogen or tungsten light should be provided. Fluorescent light will degrade the picture quality.
- This feature requires ample light. More light is required for the fastest shutter speeds.
- The Auto Focus system may not operate properly in insufficient light when using the High Speed Shutter.
- When PROG.AE is ON, you cannot manually select the shutter speed.
- When MagicPix is ON, H.S.S. cannot manually select the shutter speed.

Advanced Settings

Adjusting the Iris Manually

Normally, the Palmcorder adjusts the exposure automatically. However, when the background is extremely bright, or when the subject is backlit, you can compensate by adjusting the Iris manually.

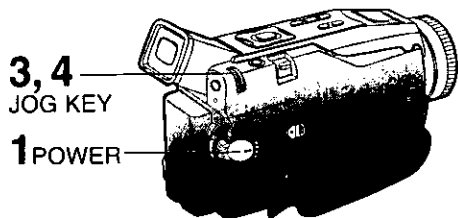

3, 4
JOG KEY

1
POWER

2
AUTO/MANUAL

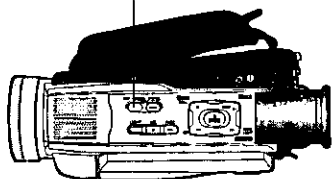

EVF/LCD

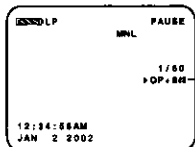

Iris
Setting

- 1 Set **POWER** to **CAMERA**.
- 2 Hold down **AUTO/MANUAL** for more than 0.7 seconds so that the "MNL" indication appears in the EVF or the LCD monitor.
- 3 Press **JOG KEY** repeatedly so that Iris setting indication appears in the EVF or the LCD monitor.
- 4 Rotate **JOG KEY** to adjust the iris;
 - When a value closer to "CLOSE" is selected, the image becomes darker.
 - When a value closer to "OP+18dB" is selected, the image becomes brighter.
 - Hold down **AUTO/MANUAL** for more than 0.7 seconds to cancel the setting.

Note

- The value to which +dB is attached indicates a gain value. If this value is too large, the quality of the image deteriorates.
- Depending on **ZOOM** magnification, the iris value may not be displayed correctly.
- If you are using Program **AE** mode, you cannot adjust the iris. If the iris is adjusted manually, the above modes will be canceled.

WIND-CUT

You can reduce sound distortion caused by wind hitting the microphone.

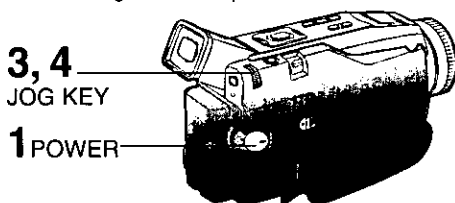

3, 4
JOG KEY

1
POWER

2
MENU

5
REC/PAUSE

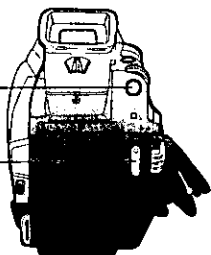

- 1 Set **POWER** to **CAMERA**.
- 2 Press **MENU** to display the **CAMERA** mode menu screen.
- 3 Rotate **JOG KEY** to select **REC MODE**, then press **JOG KEY** to display the **CAMERA REC-MODE** menu screen.
- 4 Rotate **JOG KEY** to select **WIND-CUT**, and then press **JOG KEY** to select **ON**.
 - Press **MENU** twice to exit.
 - "WIND-CUT" will appear in the EVF or LCD monitor.
- 5 Start recording.

Playback Your Recordings

Playback using the LCD Monitor

You can also use the LCD monitor to playback your recording.

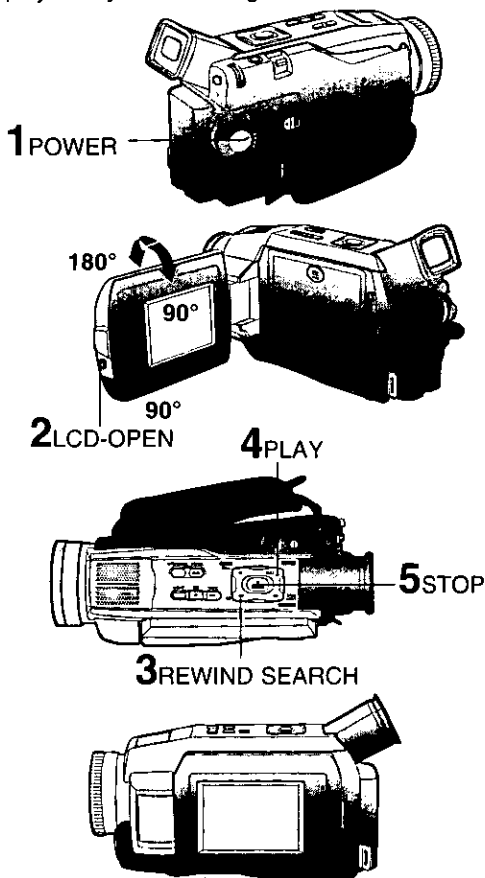

Before you begin

- Connect the Palmcorder to a power source. (pp. 13, 14)
- Insert a recorded cassette.

- 1 Set the **POWER** to **VCR**.
 - The **POWER** lamp lights red.
 - Be sure **POWER** is fully turned to the **VCR** position.
- 2 Press **LCD-OPEN** to unlock the LCD monitor and swing open.
- 3 Press **◀ (REWIND/SEARCH)** to rewind the tape.
- 4 Press **▶ (PLAY)** to start playback.
- 5 Press **■ (STOP)** to stop playback.
 - When the tape reaches its beginning during rewind or rewind search, it will stop automatically.

Note

- When a tape recorded in LP mode on another digital video camera is played back on this unit, the picture may appear mosaic.
- Using the LCD monitor reduces battery operating time.
- You can place the Palmcorder on a table, etc. for viewing. Rotate the LCD Monitor 180° and swing it up against the Palmcorder body as shown.

Connecting Earphone (not supplied)

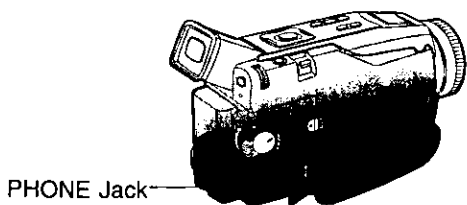

You can connect earphones (not supplied) to the PHONE Jack.

VCR

Playback Your Recordings

Repeat Playback

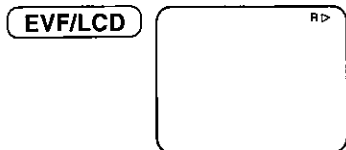
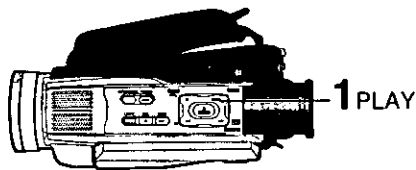

- 1 Press **PLAY** for more than 5 seconds in STOP mode.
 - The Palmcorder will go into Repeat Playback mode when the tape reaches its end.
 - The letter "R ▷" will appear in the EVF and LCD monitor.

- 2 Turn the Palmcorder **OFF** to exit the Repeat Playback mode.

Adjusting the Volume

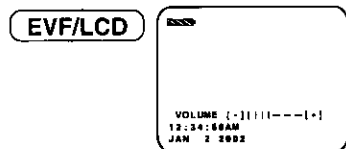
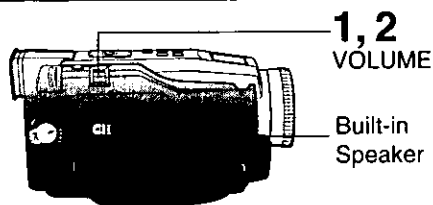

- 1 Rotate **VOLUME** to adjust the volume of the built-in speaker in PLAY mode.
 - The volume setting screen appears.

- 2 Press "T" to increase the volume or press "W" to decrease the volume.

Blank Search

You can go directly to a blank portion of tape and start recording exactly where you left off.

3, 4, 5
JOG KEY

2 MENU

1 POWER

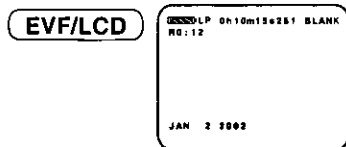
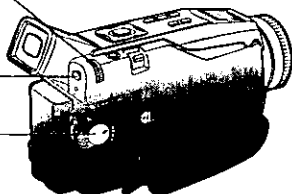

- 1 Set **POWER** to VCR.

- 2 Press **MENU** to display the VCR mode menu screen.

- 3 Rotate **JOG KEY** to select **PLAY MODE**, then press **JOG KEY** to display the VCR PLAY MODE menu screen.

- 4 Rotate **JOG KEY** to select **B.SEARCH** in the VCR PLAY MODE menu. (Menu OSD: p. 106)

- 5 Press **JOG KEY** to select ON.
 - "BLANK" will appear on the screen.

Special Effect Features

Note

- Sound is muted during all special effects.

Rapid Visual Search

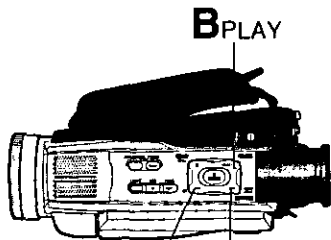

A, B REWIND/SEARCH **A, B** FAST FORWARD/SEARCH

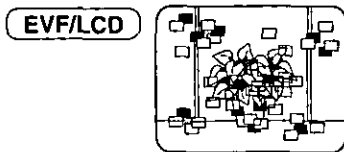

A During playback, hold down ►► (FAST FORWARD/SEARCH) or ◀◀ (REWIND/SEARCH). The search will continue for as long as the button is held down.

OR

B Press ►► (FAST FORWARD/SEARCH) or ◀◀ (REWIND/SEARCH) once for a continuous rapid visual search. Press ► (PLAY) to release.

Note

- When executing a rapid visual search, the picture may become bluish for an instant or mosaic. This is normal during this mode.

STILL Picture

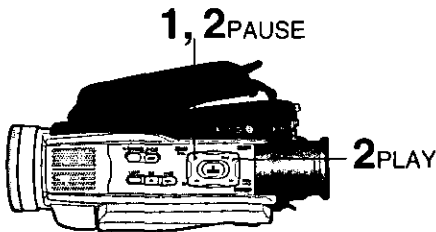

1 Press II (PAUSE) during playback.

2 Press ► (PLAY) or II (PAUSE) to release.

Note

- To protect the tape and video heads, your Palmcorder's operating modes will revert as follows:
STILL → STOP (after 3 minutes.)

Fast Forward/Rewind Check

Monitor normal picture playback during fast forward or rewind.

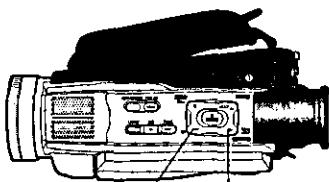

B REWIND/SEARCH **A** FAST FORWARD/SEARCH

A Hold down ►► (FAST FORWARD/SEARCH) during fast forward.

B Hold down ◀◀ (REWIND/SEARCH) during rewind.

- The picture will appear for as long as the button is held down.

Special Effect Feature

Note

- Sound is muted during all special effects.

Slow Motion Playback (Optional Remote Control Only)

Optional

2 **PLAY**

1 **▶ SLOW/
F.ADV**

1 **◀ SLOW/
F.ADV**

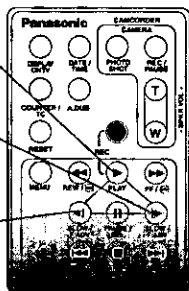

- 1 Forward Slow:
Press **▶ SLOW/F.ADV** during play.
Reverse Slow:
Press **◀ SLOW/F.ADV** during play.

- 2 Press **PLAY** to release. (During reverse slow motion playback, time code indication may not change regularly.)

Note

- Palmcorder will automatically STOP when in slow motion for more than 10 minutes.
- During slow motion playback, picture may move up and down. This is normal.
- When you start or stop slow motion playback, the picture may become bluish for an instant.

Variable Speed Search

2, 3
JOG KEY

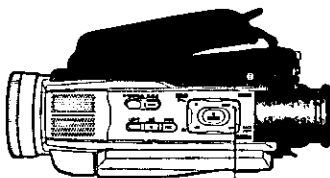
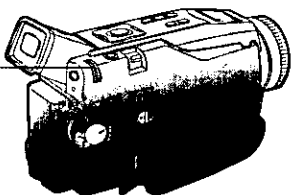

1 **PLAY**

- 1 Press **▶ (PLAY)** to start playback.
- 2 Press **JOG KEY** for about 1 second.
- 3 Rotate **JOG KEY** to adjust the playback speed.
 - Rotate **JOG KEY** clockwise for forward playback.
 - Rotate **JOG KEY** counterclockwise for reverse playback.

To return to normal playback:

Press **▶ (PLAY)**. Playback will continue at normal speed.

Note

- The Variable Speed Search function offers a choice of six playback speeds (1/5X (LP mode: 1/3X), 1X, 2X, 5X, 10X, 20X) both in forward and reverse directions.
- The review playback at the 1X speed is playback in reverse direction.
- During the Variable Speed Search (at a speed other than 1X), mosaic-like patterns will appear in the picture.
- During the Variable Speed Search, sound is muted.

Special Effect Features

Note

- Sound is muted during all special effects.

Frame by Frame Advance (Optional Remote Control Only)

Optional

3 PLAY

1 PAUSE

2 ◀ SLOW/
F.ADV

2 ▶ SLOW/
F.ADV

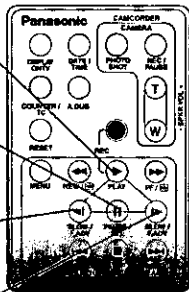

1 Press **PAUSE** during playback.

2 Press **▶ SLOW/F.ADV** to do a frame by frame advance.

Press **◀ SLOW/F.ADV** to do a frame by frame reverse.

3 Press **PLAY** to release.

Note

- If you hold down **SLOW/F.ADV**, you can see a continuous series of still images at a slower speed than normal slow mode.
- During frame by frame advance, a few frames may move automatically, and the picture may become bluish for an instant.

Index Search (Photo/Scene) (Optional Remote Control Only)

2, 3
JOG KEY

1 MENU

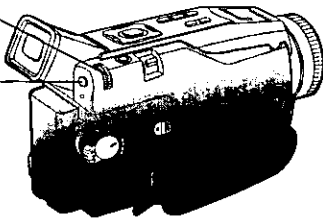

1 Press **MENU** to display the VCR mode menu screen.

2 Rotate **JOG KEY** to select **PLAY MODE**, and press **JOG KEY** to display the VCR PLAY MODE menu screen.

3 Rotate **JOG KEY** to select **INDEX**, and press **JOG KEY** to select **PHOTO** or **SCENE**.
• Press **MENU** twice to exit.

4 Press **INDEX SEARCH fast forward** or **rewind** on the remote control to advance or rewind the tape to playback a PhotoShot scene. To view the next PhotoShot, **INDEX SEARCH** must be pressed again.

Note

- The picture quality will deteriorate slightly.
- The tape remaining indicator will not appear while the **PHOTOSHOT** feature is used.
- In the Photo/Scene Index Search mode, the shutter sound effect may not be able to be heard even when **SHUTTER** is set to **ON**.
- Photo Index Search may fail to detect a recorded PhotoShot image if the image is 3 seconds or less.

Optional

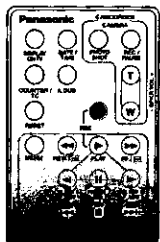

4 **INDEX SEARCH**
(fast forward)

4 **INDEX SEARCH**
(rewind)

VCR

Special Effect Features

Note

- Sound is muted during all special effects.

Jog Frame by Frame Search (Palmcorder Only)

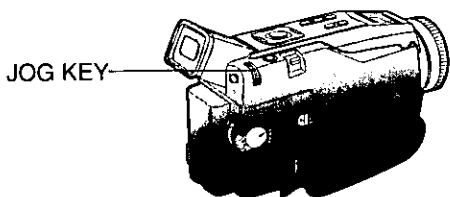

During Still mode, rotate **JOG KEY** to advance or reverse the picture one frame at a time.

Index Forward/Reverse Search (Optional Remote Control Only)

Search for a particular scene by using the electronic index marks placed at the beginning of each recording.

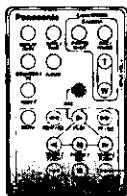
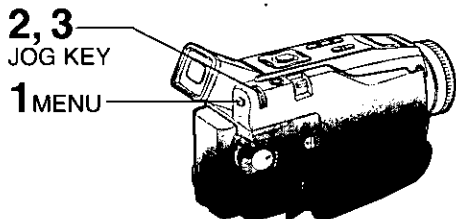

Optional

B INDEX SEARCH (rewind)

B INDEX SEARCH (fast forward)

Top Scan

If you hold down **INDEX SEARCH** more than 2 seconds, the Palmcorder will scan for scenes (or PhotoShots) and playback the first few seconds of each.

To cancel this function, press **PLAY** or **STOP**.

Note

- Search will not work if there is succession of PhotoShots.

- 1** Press **MENU** to display the VCR mode menu screen.
- 2** Rotate **JOG KEY** to select **PLAY MODE**, then press **JOG KEY** to display the VCR PLAY MODE menu screen.
- 3** Rotate **JOG KEY** to select **INDEX**, and then press **JOG KEY** to select **PHOTO** or **SCENE**. (Menu OSD; p. 106)
 - Press **MENU** twice to exit.

- A** Place the Palmcorder in the VCR **STOP** mode.
- B** Press **INDEX SEARCH** fast forward or rewind for the number of recordings (indexes) forward or back you want to view. The Palmcorder will advance or rewind to the desired recording and automatically start playback.
 - The number of times you pressed the button is displayed in the EVF and the LCD monitor if you set **INDEX** on the VCR menu to **SCENE**. (Menu OSD; p. 106) (Ex., if you press the button three times, "S3" will appear.)
 - If the interval between scenes is less than 1 minute, index search may not operate properly.
 - Response time from pressing the button and the change in the scene number is quite slow. Do not press **INDEX SEARCH** rapidly and continuously.
 - During Reverse Index Search mode, playback will not begin when a tape rewinds all the way to the beginning.

Special Effect Features

Strobe Multi Mode

In Strobe Multi Mode, you can select the rate at which a succession of still screens are captured from the playback picture.

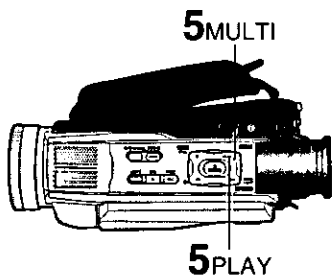
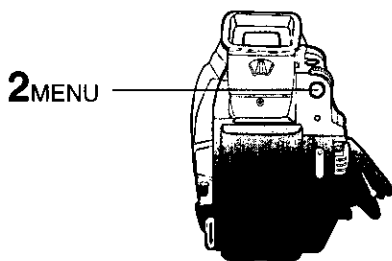
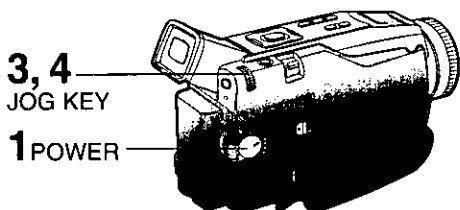

Note

- A Multi Image Playback screen cannot be output from the DV terminal or Digital Still Image terminal.
- A Multi screen will have slightly lower image quality.

- 1 Set **POWER** to **VCR**.
- 2 Press **MENU** to display the menu screen.
- 3 Rotate and press **JOG KEY** to select and set **MULTI SETTING**.
- 4 Press **JOG KEY** repeatedly to set desired speed.

Strobe Speeds

Strobe Speeds	9 screen capture time
FAST	Every 0.3 seconds
NORM	Every 0.6 seconds
SLOW	Every 1.0 seconds

- Press **MENU** twice to exit.

- 5 Press **▶ (PLAY)** to start playback. Press **▶ (MULTI)** at the point you want to start capturing.
- A succession of 9 screens will be captured, and playback will stop.

EVF/LCD

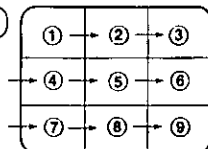

- Press **▶ (PLAY)** to start playback. Press **■ (STOP)** to stop playback.

VCR

Special Effect Features

View Recording/Playback on your TV

[TV with AUDIO/VIDEO IN Jacks]

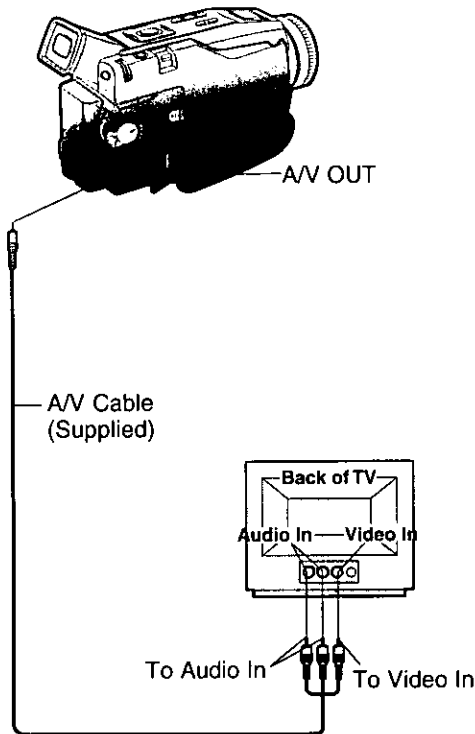

1 Set **POWER** to **CAMERA** or **VCR**.
To view what the Palmcorder is recording or to playback a tape on your TV.

2 Turn your TV **ON** and set it to **LINE INPUT**.
Check your TV operating instructions for further information.

3 Start playback or begin a recording.

- Make sure the Palmcorder and TV are turned off while connecting.
- Please connect the AV Cable securely.

Note

(Optional Remote Control Only)

You can display the various EVF and LCD indications on your TV by pressing **DISPLAY ON TV** on remote control. Press again to remove the indications.

Optional

DISPLAY
ON TV

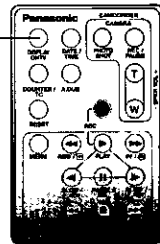

Digital Zoom

This feature is useful when you want to record close-up shots of subjects located beyond a normal zoom range of 1X to 10X magnification. With the digital zooming feature, you can select a magnification of 25X or even to 700X.

Note

- Other Digital Functions are turned off automatically when the EIS and Digital Zoom are selected.

EVF/LCD

Zoom In ("T")



Zoom Out ("W")

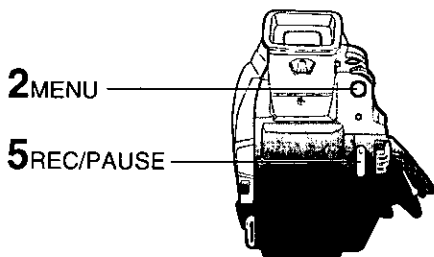
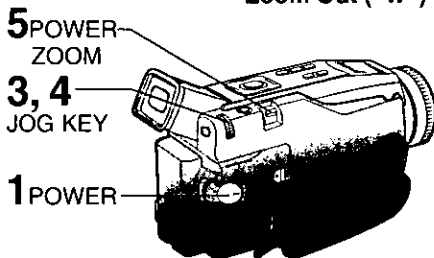

CAMERA mode

- 1 Set **POWER** to **CAMERA**.
- 2 Press **MENU** to display the **CAMERA MENU** screen.
- 3 Rotate **JOG KEY** to select **D.FUNCTION**, then press **JOG KEY** to display the **CAMERA FUNCTION** menu screen.
- 4 Rotate **JOG KEY** to select **D.ZOOM**, then press **JOG KEY** to select **D.ZOOM1** or **D.ZOOM2**.
D.ZOOM1 : from 10X to 25X
D.ZOOM2 : from 10X to 700X
OFF : Turn off D.ZOOM
• Press **MENU** twice to exit.
- 5 Press **REC/PAUSE** to start recording and press **POWER ZOOM** to zoom in or zoom out.
 - The magnification level is always displayed in the EVF or the LCD monitor when **DISPLAY** is set to **ON**. (Menu OSD: pp. 105, 107)
- 6 Repeat steps 2~4 to select **OFF** to cancel this feature.

Note

- The normal optical zoom functions from 1X to 10X.
- As magnification increases, resolution significantly decreases.
- Because the image is enlarged digitally, the picture may become distorted when higher magnification levels are used.
- When the level falls below 10X, the normal zooming function will resume.
- Focus distance becomes 1.2 m (4 feet) if the lens is in full telephoto.

(Continued on next page.)

Digital Features

Digital Zoom (Continued)

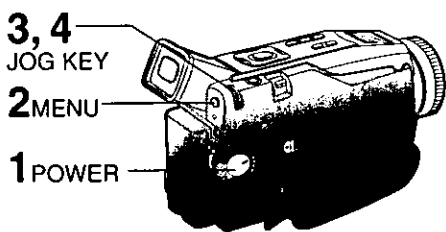

MagicPix™ Images

Color recording of video or still images onto the Mini DV tape in low lighting.
(pp. 42, 104)

Note

- MagicPix cannot be used with still images on the Memory Card.
(See "Card PhotoShot" on page 47.)

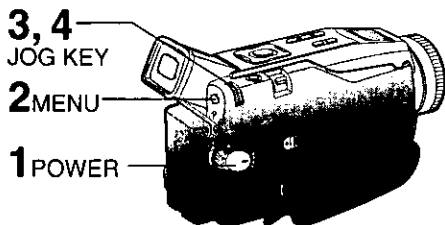

EVF/LCD



VCR mode

- 1 Set **POWER** to **VCR**.
- 2 Press **MENU** to display the **VCR MENU** screen.
- 3 Rotate **JOG KEY** to select **PLAY FUNCTION**, then press **JOG KEY** to display the **VCR PLAY FUNCTION** menu screen.
- 4 Rotate **JOG KEY** to select **D.ZOOM**, then press **JOG KEY** to select **ON**.
 - Press **MENU** twice to exit.
- 5 Press **▶ (PLAY)** to start playback.
 - The center portion of the image doubles in size.
- 6 Repeat steps 2-4 to select **OFF** to cancel this feature.

- 1 Set **POWER** to **CAMERA**.
- 2 Press **MENU** to display the menu screen.
- 3 Rotate **JOG KEY** to select **D.FUNCTION**, and then press **JOG KEY** to display the **CAMERA FUNCTION** menu screen.
- 4 Rotate **JOG KEY** to select **D.FUNCTION**, and then press **JOG KEY** repeatedly to select **MAGICPIX**.
 - Press **MENU** twice to exit.
- 5 To cancel the Digital Function, press **JOG KEY** repeatedly to select **OFF**.

Dual Digital Electronic Image Stabilization System (D.E.I.S.)

This feature helps compensate for any unintentional hand or body movement. It can be used in both the Recording and Playback (VCR) modes.

Note

- Other Digital Functions are turned off automatically when the EIS and Digital Zoom are selected.

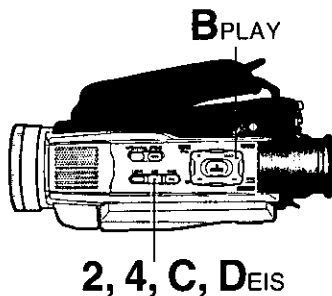
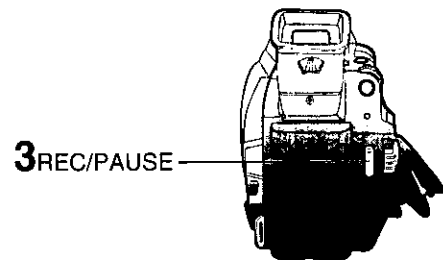
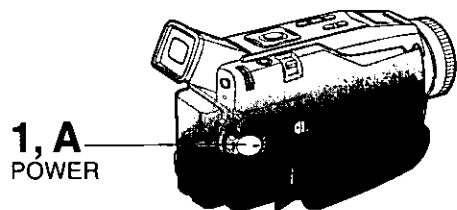
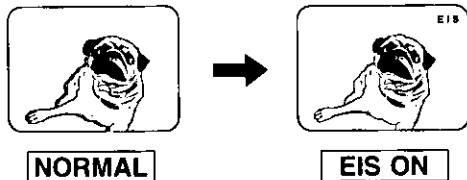

CAMERA mode

- 1** Set **POWER** to **CAMERA**.
- 2** Press **EIS** to stabilize the picture.
 - Picture flicker may be observed when taping under fluorescent lighting conditions.
 - The EIS indicator flashes when the light level is inadequate.
 - Turn D.E.I.S. OFF during recording when using a tripod.
- 3** Press **REC/PAUSE** to start recording.
- 4** Press **EIS** again to cancel.
 - Be sure that D.E.I.S. is turned off when not needed.

D.E.I.S. may not function when...

- Palmcorder movement is too extreme.
- Recording a subject with distinct horizontal or vertical stripes.
- Recording in low light situations.
- Recording a subject under a great amount of fluorescent light.
- Recording a scene with very fast motions.

VCR mode

- A** Set **POWER** to **VCR**.
- B** Press **▶ (PLAY)** to start playback.
- C** Press **EIS** to stabilize the picture.
- D** Press **EIS** again to cancel.
 - Be sure that D.E.I.S. is turned off when not needed.

Note

- When using D.E.I.S. in VCR mode, the image size is slightly larger.

Digital Features

Other Digital Functions

Use the following features to add interest and professionalism to your recordings or playback. Select from twelve special effects.

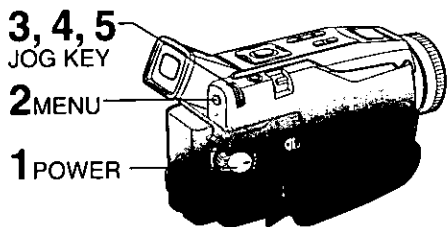

Types of Digital Functions

MIRROR

Symmetrical image from the current camera picture.

STROBE

The recording appears as a sequence of still frames.

MOSAIC

The picture appears in a mosaic pattern.

SLIM

The picture is expanded vertically.

TRAIL

The subject being recorded creates a trail when in motion.

STRETCH

The picture is expanded horizontally.

MAGICPIX (Not available during playback)

Color recording of video or still images onto the Mini DV in low lighting. (p. 40)

- Only Manual Focus is available.

WIPE

Successive scenes are separated in a way which simulates the drawing of a curtain.

MIX

The current scene is mixed in with the following scene during scene changes.

PinP

PinP (Still image) is displayed on the Main Picture.

SEPIA (Only available during playback)

The picture is played back in sepia, a brownish color, giving it an antique look.

MONO (Monotone) (Only available during playback)

The picture is played back in black-and-white.

42

1 Set **POWER** to **CAMERA** or **VCR**.

2 Press **MENU** to display the menu screen.

3 Rotate **JOG KEY** to select **D.FUNCTION** in the **CAMERA** mode menu screen or **PLAY FUNCTION** in the **VCR** mode menu screen, then press **JOG KEY** to display the **CAMERA FUNCTION** or **VCR PLAY FUNCTION** menu screen.

4 Rotate **JOG KEY** to select **D.FUNCTION**, and then press **JOG KEY** repeatedly to select one of the Digital Functions listed on the left.

5 To cancel the Digital Function, press **JOG KEY** repeatedly to select **OFF**.

Note

- The **EIS** and **Digital Zoom** features are turned off automatically when one of the Digital Functions listed at left is selected.

To use the WIPE function

- In Camera mode, set the "D.FUNCTION" item in the main menu screen to "WIPE". (Menu OSD: p. 104)
- Press **REC/PAUSE** to start recording.
- Press **REC/PAUSE** to pause the recording. The last scene will be memorized.
- Press **RECORD/PAUSE** to start recording again. The new scene will take the place of the memorized scene.

To use the MIX function

- In Camera mode, set the "D.FUNCTION" item in the main menu screen to "MIX" (Menu OSD: p. 104). Then, perform steps b-d above.

The memorized scene and the new scene will appear mixed as the scene changes from one to the other.

Note

- When **Photo Title** is set, **WIPE/MIX** mode becomes **Photo Title**. When **Photo Title** is finished, Digital Function turns **OFF**.

Audio Dubbing using the Built-in Microphone

The original sound can be replaced with new sound using the built-in Palmcorder microphone.

Built-in Microphone

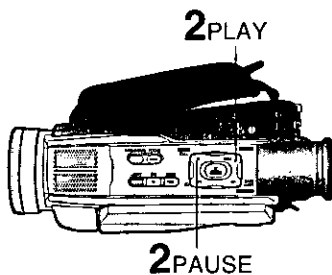
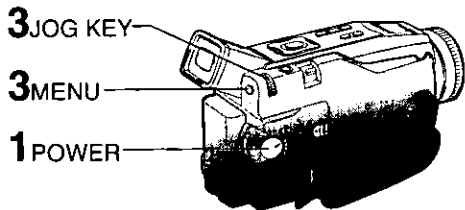
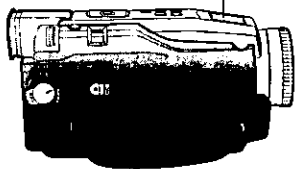

Optional

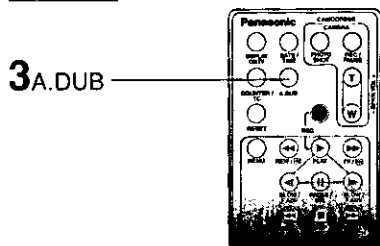

Before you begin

- Turn on the Palmcorder.
- Insert a pre-recorded tape to be dubbed.

The AUDIO-REC setting in CAMERA MENU mode should be as follows:

12 bit	The original sound is recorded on ST (Stereo) 1, and the new sound will be recorded on ST (Stereo) 2.
16 bit	The original sound is replaced with the new sound.

- Select 12 bit if you do not want the original sound to be completely replaced during an audio dub.
- If you dub over a tape which has both 12 bit and 16 bit audio recordings on it, keep in mind that the original 16 bit audio portion will be completely replaced.

1

Set **POWER** to **VCR**.

- If you have the optional Remote Control, you can set the Palmcorder to stop automatically at a specified point on the tape. See "Memory-Stop Editing" on page 44.

2

Press **▶ (PLAY)**. Then press **II (PAUSE)** where you want dubbing to begin.

When using the Palmcorder only

3

Press **MENU** to display the VCR mode menu screen.

Rotate **JOG KEY** to select **REC MODE**, then press **JOG KEY** to display the VCR REC MODE menu screen.

Rotate **JOG KEY** to select **AUDIO-DUB**, and then press **JOG KEY** to select **ON**.

- The Palmcorder will go to Stand By mode, and "A.DUB" flashes in the EVF or the LCD monitor. Go to step 4.

When using the Optional Remote Control only

3

Press **A.DUB** on the Remote Control.

- The Palmcorder will go to Stand By mode, and "A.DUB" flashes in the EVF or the LCD monitor. Go to step 4.

(Continued on next page.)

Editing Features

4, 5 PAUSE

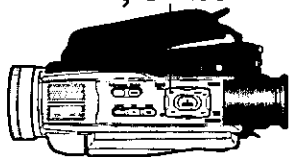

To listen to the desired audio sound, set the AUDIO setting of the VCR mode MENU (Menu OSD: p. 106) as follows:

AUDIO: The following selections are available for 12 bit AUDIO dubbed recordings only (sound recorded in SP mode only).

ST 1	Set this position to listen to the original sound.
ST 2	Set this position to listen to the audio dubbed sound.
MIX	Set this position to listen to both the original sound and the audio dubbed sound.

Note

- 16 bit dubbed sound completely erases the original 16 bit recorded sound.
- If you dubbed using 12 bit AUDIO recording and then selected AUDIO-MIX in the menu for playback, the sound will be stereo regardless of the AUDIO-OUT setting.
- If you recorded in LP mode, you cannot use the A.DUB feature.

Memory-Stop Editing (Optional Remote Control Only)

You can set an automatic Dubbing stop point.

Optional

D RESET

A MENU

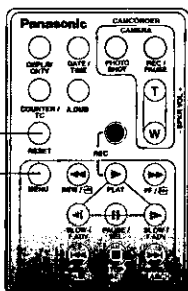

4 Press II (PAUSE) to start Audio Dubbing.

- Connect the Palmcorder to the TV in order to monitor the sound. (p. 38)



Only NTSC (National Television Standards Committee) recorded tapes can be audio dubbed. The following screen appears if the tape was not recorded in NTSC format.

5 Press II (PAUSE) to stop Audio Dubbing.

- If the microphone used for dubbing gets too near the speaker of your TV, a howling noise (feedback) may occur.
- If the tape position is in or was started in a blank section, you cannot use the A.DUB feature.

A Press MENU to display the VCR menu screen.

B Rotate JOG KEY to select **DISPLAY SETTING**, and then press JOG KEY to display the DISPLAY SETTING menu.

C Rotate JOG KEY to select **DISPLAY**, and then press JOG KEY to set to MEMORY.

D Press MENU two times to exit MENU mode. Then, press RESET on the remote control to reset the Counter Memory to M 0:00:00.

Now, rewind to the editing start point, and continue with steps 2-5. The tape will now stop automatically at "M 0:00:00".

Copying your Tapes to VHS Cassette

Source (Playing)
Palmcorder

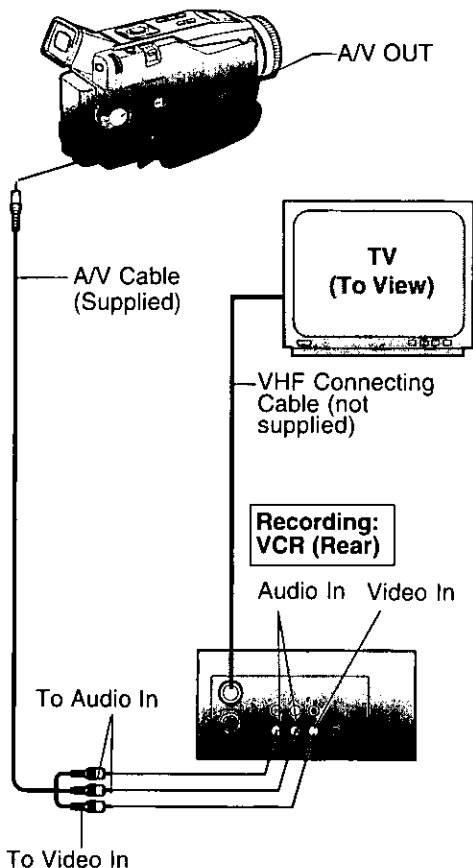

Before you begin

- Connect both Palmcorder and VCR to their power sources.
- Connect the Palmcorder to a VCR as illustrated left.
- Turn ON both units.
- **Set the recording VCR's Input Signal Selector to LINE.**
- Set the Palmcorder POWER to VCR.

- 1** Insert a pre-recorded tape into the source (playing) Palmcorder and a blank tape, with record tab in place, into the target VCR (Recorder).
- 2** Press ► (PLAY) on the Palmcorder. When the tape reaches the point you want to start dubbing, press PAUSE.
- 3** Place the VCR into REC/PAUSE mode. (See VCR manual.)
- 4** Simultaneously, press PAUSE on both units to begin copying.
- 5** Press STOP on both units when copying is completed.

Note

- For technical reasons, dubbing a tape may reduce its quality.
- Press DISPLAY ON TV on the Palmcorder Remote Control (optional) to eliminate EVF/LCD Monitor indications.
- If the Time Code is displayed in the EVF or LCD monitor, it cannot be reset.
- Only the DATE/TIME, when displayed, will be recorded on the tape.

Monitor with your TV

- Turn the TV ON and select its VCR channel (either CH3 or CH4).
- Set the VCR/TV Selector on the recording VCR to VCR.

CAUTION:

Unauthorized exchanging and/or copying of copyrighted recordings may be copyright infringement.

Editing Features

Copying from Digital Equipment (dubbing)

High quality digital-to-digital copying can be accomplished if both Palmcorders incorporate the DV Input/Output (i.LINK) Connector (DV interface cable (i.LINK) is not supplied).

Source (Playing) Palmcorder

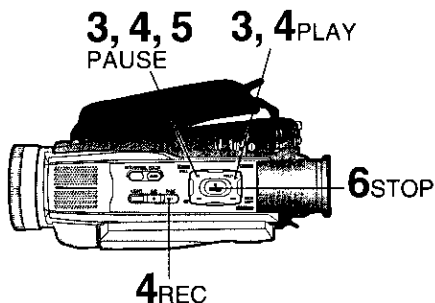
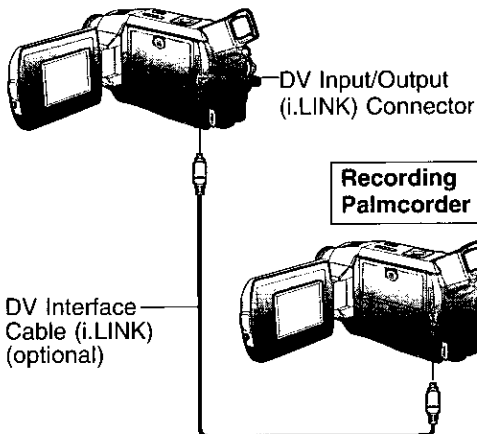

Optional

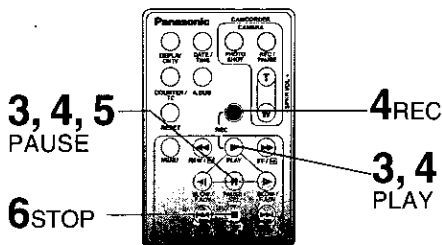

Before you begin

- Connect both Palmcorders to their power sources.
- Connect the two Palmcorders using the DV interface cable (i.LINK) (4-pin to 4-pin).
- Turn both Palmcorders ON.

- 1** Insert a pre-recorded tape into the source (playing) Palmcorder, and set **POWER** to **VCR**.
- 2** Insert a blank tape with the record tab closed into the target (recording) Palmcorder and set **POWER** to **VCR**.
- 3** Press **▶ (PLAY)** on the source Palmcorder. When the tape reaches the point you want to start dubbing, press **⏸ (PAUSE)**.
- 4** Hold down **REC** and press **▶ (PLAY)** on the target (recording) Palmcorder or on the remote control (optional). Press **⏸ (PAUSE)** to pause the tape at the starting point of the dub.
- 5** Simultaneously, press **⏸ (PAUSE)** on both units to begin dubbing.
- 6** Press **■ (STOP)** on the recording unit, and then press **■ (STOP)** on the playing unit to end dubbing.

Note

- When two Palmcorders are used for dubbing, it is recommended that the Remote Control (optional) VCR1 or VCR2 setting be used to avoid improper operation.
- When two Palmcorders are connected using the DV interface cable (i.LINK) (not supplied), a Video Editing Controller cannot be used.
- Do not connect both an A/V Cable and a DV Interface Cable (i.LINK).

CAUTION:

Unauthorized exchanging and/or copying of copyrighted recordings may be copyright infringement.

Card (Optional) Features

Card PhotoShot

You can record still images to a Memory Card.

Warning

- Memory Card will not work when DV interface Cable (i.LINK) is connected.

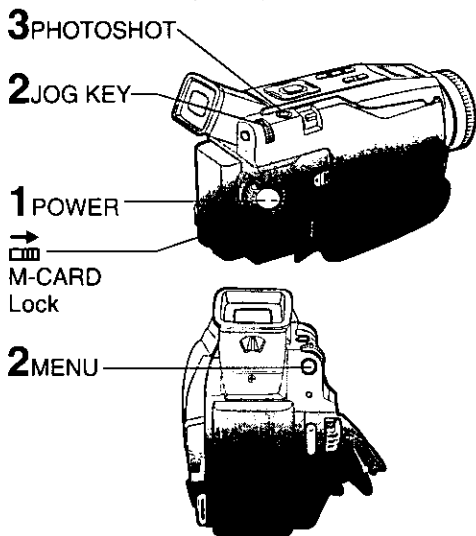

Image Resolution and Capacity (Optional 8MB Memory Card)

REC Mode	Image Resolution	Capacity
FINE	1280 x 960	Approx. 30 images
NORMAL	640 x 480	Approx. 70 images

- The number of images given for each mode applies when all images are taken in same mode.
- You can change recording modes at any time before capturing an image.
- The number of images that can be captured may differ depending on the subject. After capturing an image, the number may not decrease, or it may decrease by two. This is normal.

Warning

- While "PROCESSING" is displayed, **DO NOT turn off the Palmcorder or unplug the AC Adaptor** (supplied) because this will cause irreversible damage to the memory.

Before you begin

- Connect the Palmcorder to a power source. (pp. 13, 14)
- Set POWER to OFF before inserting a Memory Card. (p. 12)

- 1 Slide the M-CARD Lock Switch to unlock, then set POWER to M-CARD.
 - The POWER lamp lights red.
 - Be sure POWER is fully turned to M-CARD position.
 - "PLAY: PUSH PLAY KEY" is displayed for 10 seconds. (p. 49)
- 2 Press MENU to display CARD SETTING menu, then press JOG KEY to select **NORMAL** or **FINE**.

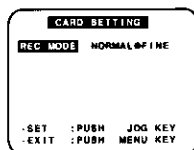

- Press MENU to exit this menu.

- 3 Press PHOTOSHOT to record an image.

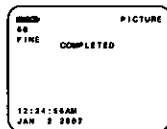
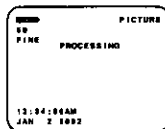

- The PhotoShot image is recorded to the Memory Card.
- When SHUTTER is set to ON (Menu OSD: p. 104), still pictures are recorded with a visual shutter effect and click sound. If set to OFF, the still image will be displayed only.

Card (Optional) Features

Cautions for the Memory Card

- While Memory Card data is being read, do not remove it, turn off the power, or subject unit to vibrations and/or shocks.
- Do not leave the Memory Card in a place with high temperature, a place exposed to direct sunlight, or a place where electromagnetic waves and static electricity can be generated.
- Electromagnetic waves, static electricity, malfunction of the Digital Video Palmcorder or of the Memory Card itself could erase the data recorded on it. To prevent the loss of picture data, we recommend that you make a backup copy on the computer.
- Do not bend or drop the Memory Card as this could damage it or the captured contents.
- Do not touch the connector on the rear edge of the Memory Card with your fingers and take care that no dirt, dust or water enters it.
- Do not affix other labels to the Memory Card face or back as Card insertion/removal may become impossible.

Recording images From a Tape

You can record still images from a cassette tape to a Memory Card.

Warning

- Memory Card will not work when DV interface Cable (i.LINK) is connected.

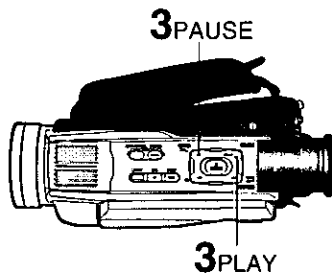
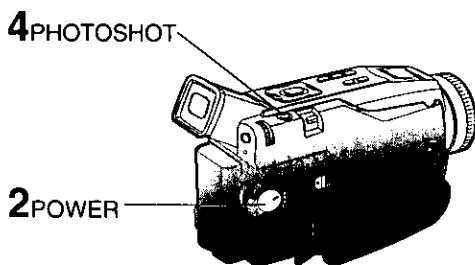

Before you begin

- Connect the Palmcorder to a power source. (pp. 13, 14)
- Set POWER to OFF before inserting a Memory Card. (p. 12)

- 1 Repeat steps 1 and 2 on page 47.
- 2 Set POWER to VCR.
- 3 Press ► (PLAY) to start playback of the cassette tape. And then, press II (PAUSE) to select an image.
- 4 Press PHOTOSHOT to record the desired image to the Memory Card.

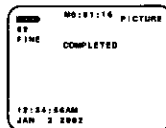
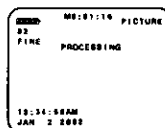

- When PHOTOSHOT is pressed in PLAY or SLOW mode, the screen goes to STOP mode.
- To playback the images of the Memory Card, see page 49.
- When Variable Speed Search is done (p. 34), this feature can not be used.

- 5 Repeat steps 3~4 to record another image to the Memory Card.

Card (Optional) Features

Playback Still Images

You can view the images on the Memory Card.

3, 4
JOG KEY

1
POWER

M-CARD
Lock

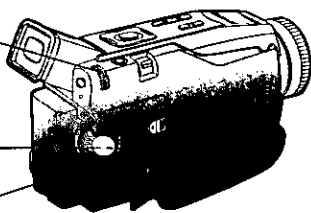

2
M-PLAY

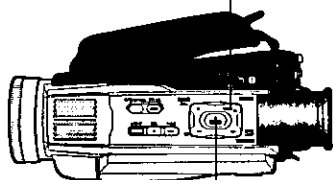

M-STOP

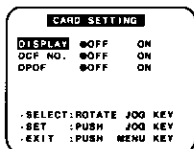

Note

- If the file number is changed, the Palmcorder cannot read the file data.
- This product is compliant with DCF (Design rule for Camera File System). Images saved on the Memory Card using other Digital Still Cameras that are compliant with DCF can be viewed on this product.

Warning

- While "PLEASE WAIT" is displayed, **DO NOT** turn off the Palmcorder or unplug the AC Adaptor (supplied) because this will cause irreversible damage to the memory.

Before you begin

- Set POWER to OFF before inserting a recorded Memory Card. (pp. 47, 48)

- 1 Slide the M-CARD Lock Switch to unlock, then set POWER to M-CARD.
 - "PLAY: PUSH PLAY KEY" is displayed for 10 seconds.

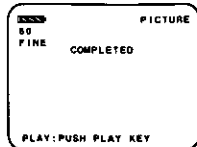

- 2 Press ► (M-PLAY) to display the Multi playback screen.
 - "PLEASE WAIT" appears on-screen.
 - Rotate JOG KEY to scroll through Multi image screen pages (6 images per page) and select an image.
 - The selected image is underlined in green.

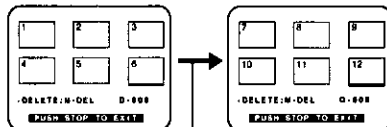

"PLEASE WAIT" is displayed.

- Press MENU to display CARD SETTING menu screen.
- Press ■ (M-STOP) to return to the Card PhotoShot REC Mode. (p. 47)

- 3 Press JOG KEY to display the selected image as a full-size screen.
 - "PLEASE WAIT" appears on-screen.

- 4 Rotate JOG KEY to select BACK (previous image), MULTI (Multi Image screen), or NEXT (next image).

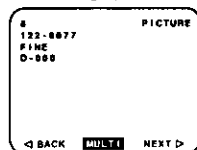

- Press ■ (M-STOP) to return to the Multi Playback screen.

Card (Optional) Features

Delete Specific Images

You can delete unwanted images and increase the remaining image memory.

Warning:

Once deleted, images cannot be restored.

DELETE PAGE

Delete specific images from a page.

DELETE ALL

Delete all images. (p. 51)

FORMAT

Delete all data. (p. 52)

3, 4, 5
JOG KEY

1 POWER
M-CARD
Lock

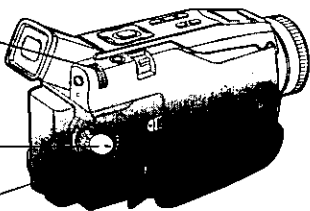

3 M-DEL

2 M-PLAY

M-STOP

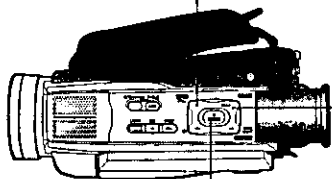

Before you begin

- Set POWER to OFF before inserting a recorded Memory Card. (pp. 47, 48)

- 1** Slide the M-CARD Lock Switch to **unlock**, then set POWER to M-CARD.
 - "PLAY: PUSH PLAY KEY" is displayed for 10 seconds.
- 2** Press **▶ (M-PLAY)** to display the Multi playback screen.
 - "PLEASE WAIT" appears on-screen.
- 3** Press **II (M-DEL)** to display the DELETE menu, then **rotate and press JOG KEY** to select **PAGE**.

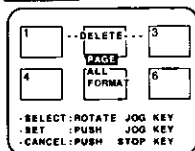

- DELETE PAGE menu is displayed.

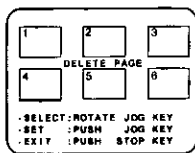

- 4** Rotate and press **JOG KEY** to select and set the image to be deleted.
 - The selected image is underlined in pink.

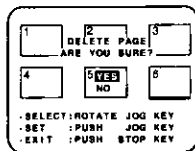

- 5** Rotate **JOG KEY** to select **YES**, and press **JOG KEY** to delete the selected image.
 - To cancel delete, press **■ (M-STOP)** or rotate and press **JOG KEY** to select NO.
 - "PLEASE WAIT" appears on-screen during deletion.
 - To delete other images, repeat steps 4-5.

Warning

- While deleting image, **DO NOT** turn off the Palmcorder or unplug the AC Adaptor (supplied) because this will cause irreversible damage to the memory, resulting in reduced image storage capacity.

Card (Optional) Features

Delete All Image Pages

You can delete all images from the Memory Card easily with this operation.

Warning:

Once deleted, images cannot be restored.

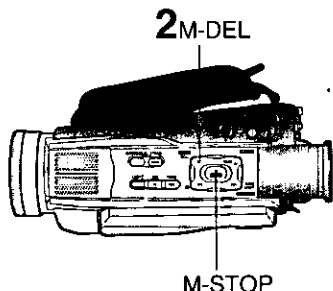
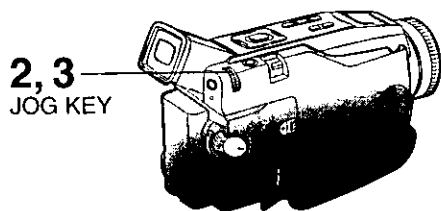

Before you begin

- Set POWER to OFF before inserting a recorded Memory Card. (pp. 47, 48)

1 Do steps 1 and 2 on page 50.

2 Press **II (M-DEL)** to display the DELETE menu. Then, rotate and press **JOG KEY** to select **ALL**.

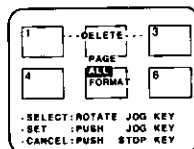

- The screen below is displayed.
- To cancel delete, press **■ (M-STOP)** or rotate and press **JOG KEY** to select **NO**.

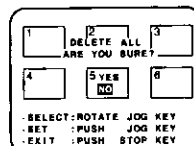

3 Rotate and press **JOG KEY** to select **YES**.

- "PLEASE WAIT" is displayed on the screen, and then "NO PICTURE" is displayed.

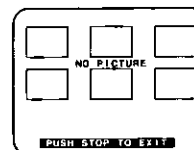

Warning

- While deleting image, **DO NOT** turn off the Digital Video Camcorder or unplug the AC Adaptor (supplied) because this will cause irreversible damage to the memory, resulting in reduced image storage capacity.

- Press **■ (M-STOP)** to return to the Card PhotoShot REC Mode screen. (p. 47)

Card (Optional) Features

Format the Memory Card

You can easily format your Memory Card using this operation.

Warning:

Formatting permanently removes all image data.

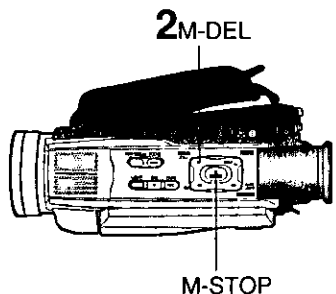
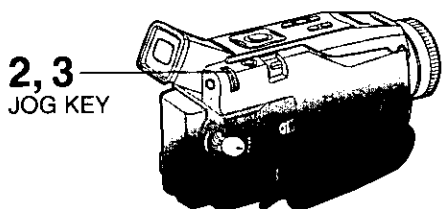

Warning

- While deleting image, **DO NOT** turn off the **Palmcorder** or **unplug the AC Adaptor (supplied)** because this will cause irreversible damage to the memory, resulting in reduced image storage capacity.

Before you begin

- Set **POWER** to **OFF** before inserting a recorded Memory Card. (pp. 47, 48)

1 Do steps 1 and 2 on page 50.

2 Press **II (M-DEL)** to display the **DELETE** menu, then **rotate and press JOG KEY** to select **FORMAT**.

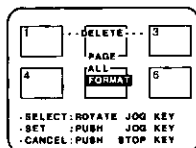

- The screen below is displayed.
- To cancel format, press **■ (M-STOP)** or rotate and press **JOG KEY** to select **NO**.

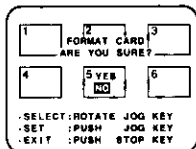

3 Rotate and press **JOG KEY** to select **YES**.

- "PLEASE WAIT" is displayed on the screen as all image data is deleted from Memory Card. Deletion is complete when "NO PICTURE" is displayed.

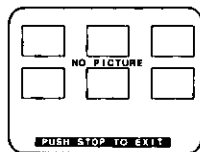

- Press **■ (M-STOP)** to return to the **Card PhotoShot REC Mode** screen. (p. 47).

Card (Optional) Features

DPOF Setting

You can select the images to be printed, the number of prints, and other print-related information (DPOF setting) on a Memory Card. "DPOF" stands for Digital Print Order Format, and since printing data can be added to images on the Memory Card, the Memory Card can be used with any system that provides DPOF.

VARIABLE:

You can select images recorded on the Memory Card and set the number of prints desired.

ALL1:

The number of prints recorded on the Memory Card is collectively set to 1.

ALL0:

The currently set number of prints is set to 0.

3, 4, 5, 6
JOG KEY

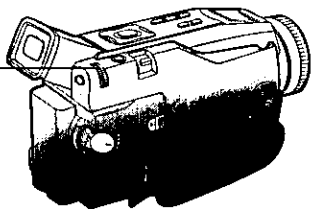

2 MENU

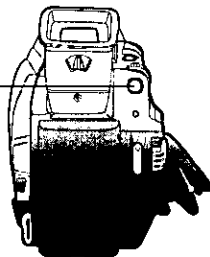

Before you begin

- Set POWER to OFF before inserting a recorded Memory Card. (pp. 47, 48)

- 1 Do steps 1 and 2 on page 50.
- 2 Press MENU to display the CARD SETTING menu screen.
- 3 Rotate JOG KEY to select **DPOF**, then press JOG KEY to select ON.

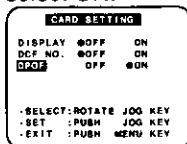

- 4 Rotate JOG KEY to select **VARIABLE**, then press JOG KEY to select ON.
 - DPOF SETTING menu screen is displayed on the screen.

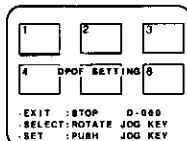
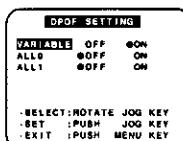

- 5 Rotate and press JOG KEY to select the picture.
 - The selected image is underlined in green
 - The cursor moves to "D-000".

- 6 Rotate and press JOG KEY to set the number of prints.
 - The "•" mark is displayed. The "•" mark indicates pictures for which 1 or more prints have been set.
 - When printing one each of all the pictures, select "ALL1"; if not all the pictures are printed, select "ALL0".

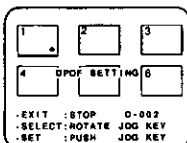

- 7 Repeat steps 5 and 6 to set the other pictures.



Print mark is based on DPOF (Digital Print Order Format).

Transferring Your Images (Windows)

You can transfer images from your Palmcorder tape to your PC (Personal Computer).

System Requirements (for Palmcorder USB Device Driver/PHOTOVU MPEG4 Movie Messenger™ System)

- IBM PC/AT or compatible
- Pentium II Processor: 266 MHz or more
- RAM: 64 MB or more
- CD-ROM drive (for installation)
- Mouse or other pointing device
- Windows 98SE/Me/2000/XP preinstalled PC with USB port
- 2 MB minimum available hard disk space (for Palmcorder USB Device Driver)
- 15 MB minimum available hard disk space (for PHOTOVU/MPEG4 Movie Messenger™ System)
- 10 MB minimum available hard disk space (for Palmcorder File Converter)
- Minimum 120 MB of free hard disk space for Motion picture transfer from DV tape to PC (for PHOTOVU/MPEG4 Movie Messenger™ System)
- Video card that supports 16 bit color at 800 x 600 monitor resolution (for Palmcorder USB Device Driver, PHOTOVU/MPEG4 Movie Messenger™ System, and Palmcorder File Converter)
- Microsoft® Windows Media™ Player 6.4 (for Windows 2000 users: Microsoft® Windows Media™ Player 7.1) or newer (for PHOTOVU/MPEG4 Movie Messenger™ System)
 - * If Windows Media Player 6.4 (for Windows 2000 users: Windows Media Player 7.1) or newer is not installed in your PC, Please download and install Windows Media Player from the Microsoft Home Page: <http://www.microsoft.com/>

*Satisfy the conditions recommended by Microsoft for Windows XP.

Palmcorder USB Device Driver/Web Camera/SD Drive

Install Palmcorder USB Device Driver.

You can transfer motion/still picture to your PC using Movie Messenger, Web Camera or SD Drive via USB. Using this driver allows data communication between the Memory Card and PC.

PHOTOVU/MPEG4 Movie Messenger™ System

Install PHOTOVU/MPEG4 Movie Messenger™ System.

You can transfer motion/still picture to your PC from DV tape via USB and i.LINK.

Palmcorder File Converter

Install File Converter.

You can convert the JPEG data of your PC into the DCF (Design rule for Camera File System) data, and transfer this data to your Palmcorder via USB. Using this driver allows data communication between the Memory Card and PC.

Transferring Your Images (Windows)

Software Installation (Windows 98SE/Me/2000/XP)

Caution

- Please install Palmcorder USB Device Driver first before connecting the Palmcorder and your PC using USB Cable. Once Palmcorder USB Device Driver is installed, you must restart your computer for installation to take effect.
- Restarting the computer not only applies to Driver installation, but must be done whenever "Restarting Windows" is displayed after software or driver install/uninstall.

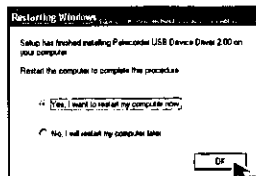

- 1 Turn on the PC (Personal Computer) and start up Windows.
- 2 Insert the supplied Software CD-ROM into the CD-ROM drive.
- 3 Click the icon you want to install. Please install the Palmcorder USB Device Driver first and follow the instructions listed under "Caution".

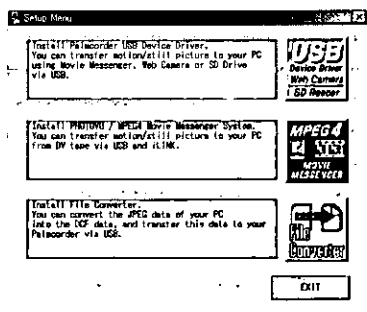

Palmcorder USB Device Driver

- For Movie Messenger
- For Web Camera
- For SD Drive

: Click



PHOTOVU/MPEG4 Movie Messenger™ System

: Click



Palmcorder File Converter

: Click



WPC Connection

- 4 Follow the instructions as they appear on your PC screen.

Note

- If a window does not appear automatically, click the "Start" button on your desktop and then click "Run". When the Run box is open, type in "D:\InstMenu.exe" where "D:" is the drive letter of your CD; then click "OK".
- If you attempt to install the next Software before the previous Software installation is completed, "Error" may appear. In this case, click [OK] and install the next Software from the menu.

Transferring Your Images (Windows)

Notes on PHOTOVU/MPEG4 Movie Messenger™ System operation

- For PHOTOVU/MPEG4 Movie Messenger™ System, do not connect the i.LINK and USB terminals to the Palmcorder at the same time.
- Make sure Palmcorder power is not shut off during use as your PC system may become unstable. Therefore, the AC Adaptor should be used as the power source. (Be especially careful when recording in M-CARD or CAMERA mode as the power eventually shuts off automatically if a tape is inserted.)
- For PHOTOVU/MPEG4 Movie Messenger™ System, if the play, stop, fast forward, and rewind functions are operated using the Palmcorder buttons, the image may not be captured properly. Use Palmcorder Operation Buttons displayed on the PC screen.

Uninstalling Application Software

[This screen is an example (Windows 2000)]

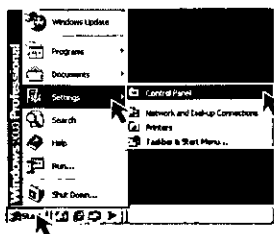

1 Click "Start," "Settings," and "Control Panel."

2 Double-click on "Add/Remove Programs" in the "Control Panel."

3 Select the application software you want to remove, and then click [Add/Remove].

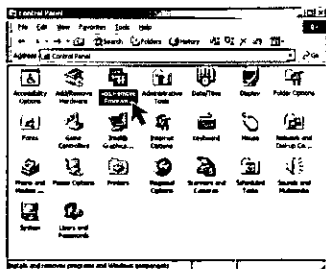

PHOTOVU/MPEG4 Movie Messenger™ System

Connection (for PHOTOVU/MPEG4 Movie Messenger™ System)

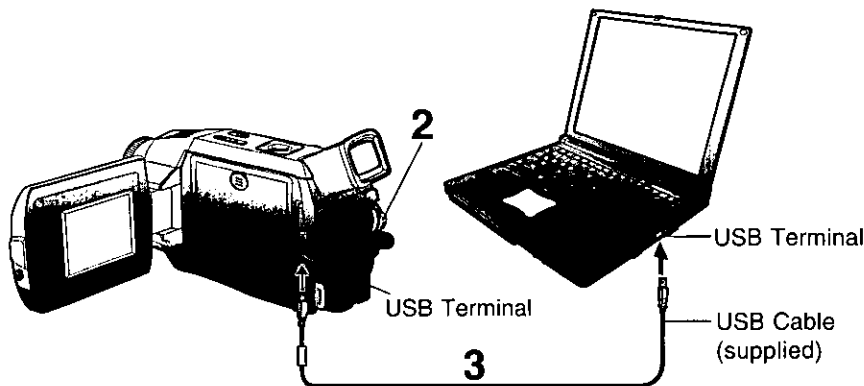

1 Turn on your PC.

2 Set the Palmcorder POWER to VCR.

For Windows XP users

3 Connect the Palmcorder to your PC (Windows) using the USB Cable (supplied).

- "CAPTURE" appears in the EVF or the LCD monitor.
- The "Found New Hardware Wizard" screen of Windows is displayed.

The following message **2** is displayed. Even so, functionality confirmation has been performed at our manufacturer.
Click [Continue Anyway] and proceed.
Follow the instructions as they appear on your PC screen.

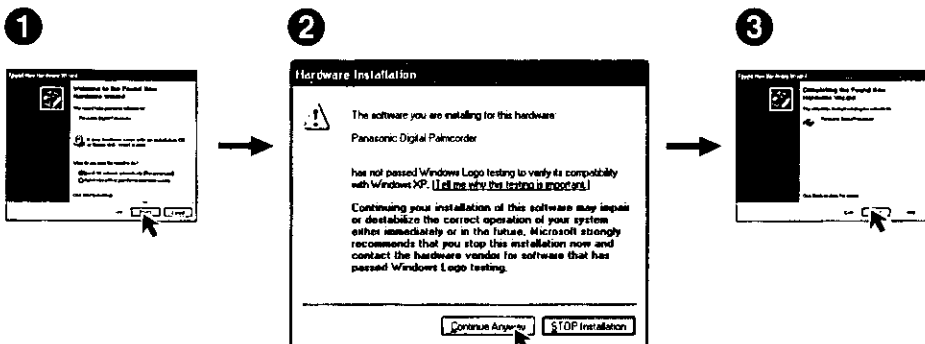

Note

• For extended use, the AC Adaptor should be used as a power source.

WPC Connection

For Windows 2000 users

- 3** Connect the Palmcorder to your PC (Windows) using the USB Cable (supplied).
- "CAPTURE" appears in the EVF or the LCD monitor.
 - The "Found New Hardware" screen of Windows is displayed.
 - When the Palmcorder and PC (with Windows 2000) are connected via USB, a message, such as the one below, is displayed.
- The following message is displayed. Even so, functionality confirmation has been performed at our manufacturer. Click [Yes] and proceed.**

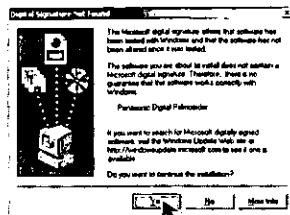

Note

- For extended use, the AC Adaptor should be used as a power source.

For Windows 98SE/Me users

- 3** Connect the Palmcorder to your PC (Windows) using the USB Cable (supplied).
- "CAPTURE" appears in the EVF or the LCD monitor.

Note

- For extended use, the AC Adaptor should be used as a power source.

PHOTOVU/MPEG4 Movie Messenger™ System

Running the PHOTOVU/ MPGE4 Movie Messenger™ System*

- * **PHOTOVU:** You can transfer Still images from your Palmcorder tape to a PC.
MPEG4 Movie Messenger™ System: You can transfer Motion images from your Palmcorder tape to a PC.

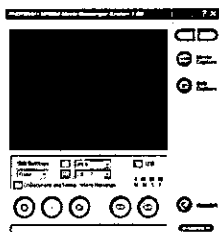
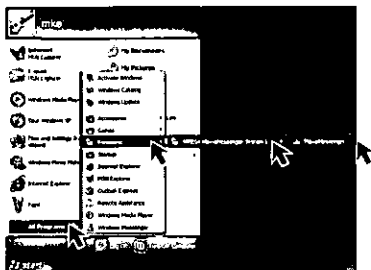

Before you begin

- Insert a recorded tape. (p. 10)

- 1** Set Palmcorder **POWER** to **VCR**.
- 2** Connect the Palmcorder to your PC using the **USB Cable** (supplied) or **DV interface Cable (i.LINK)** (not supplied). (pp. 57, 58, 69)
- 3** Click on **"Start," "(All) Programs," "Panasonic," "MPEG4 MovieMessenger System 1.00,"** then **"MovieMessenger."**
- 4** **"PHOTOVU/MPEG4 MovieMessenger System 1.00"** is opened.

Note

Refer to Help for information about application operations and Error messages.

How to insert the USB Cable or DV Interface Cable (i.LINK)

- A** Set Palmcorder **POWER** to **VCR**.
- B** Connect the Palmcorder to your PC using the **USB Cable** (supplied) or **DV interface Cable (i.LINK)**.
- C** Start up the **PHOTOVU/MPEG4 Movie Messenger™ System**.

How to remove the USB Cable or DV Interface Cable (i.LINK)

- A** Close the **PHOTOVU/MPEG4 Movie Messenger™ System**.
- B** Remove the **USB Cable** or **DV Interface Cable (i.LINK)** from the Palmcorder.
- C** Set Palmcorder **POWER** to **OFF**.

While PHOTOVU/MPEG4 Movie Messenger™ System is running, do not perform the following operations...

The PC system may become unstable.

- Change the screen area or color pallet in the Display Properties window.
- Turn the Palmcorder power switch **ON** or **OFF** while connecting the Palmcorder to your PC using the **USB Cable** or **DV Interface Cable (i.LINK)**.
- Change the Palmcorder power switch (**VCR/CAMERA**).
*You must first close the application.
- Connect/disconnect the **DV Interface Cable (i.LINK)**.
- Connect/disconnect the **USB Cable**.

PHOTOVU/MPEG4 Movie Messenger™ System

Using Tape Image Data (USB)

By connecting the Palmcorder and PC with the USB Cable, you can transfer Motion images and Still images saved on the DV Tape directly to your PC.

Note

- Detail mode cannot be used with a USB connection.
- Deactivate your PC ScreenSaver or this application may shutdown during image capture.

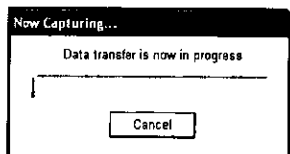
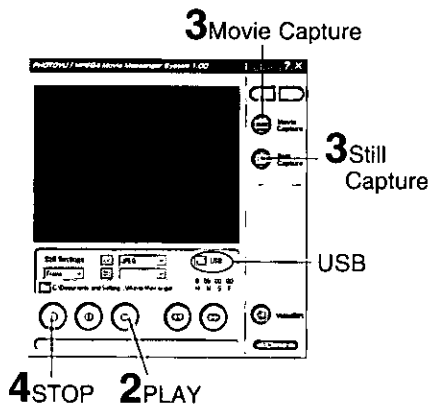

To capture Still images

- 3** Click on [Still Capture] at the point you wish to capture an image.
 - Repeat step 3 to continue capturing images.
 - Captured Still images are saved to the PC, and you can playback the saved images on the View Manager. (p. 61)

Before you begin

- Insert a recorded tape. (p. 10)
- Make Palmcorder-PC connections. (pp. 57, 58)
- Turn your PC on. (p. 57)
- Set Palmcorder POWER to VCR.

- 1** Repeat steps 1~4 on page 59 to run the PHOTOVU/MPEG4 Movie Messenger™ System.

Note

- When the USB Cable is connected, the input display will automatically become USB. If it is not USB, please confirm the connection. Then, close and restart the software.

- 2** Click ► (PLAY) on PC screen to playback the DV tape.
 - The playback screen cannot be viewed on the PC. Please use the LCD monitor on the Palmcorder for confirmation.

To capture Motion images

- 3** Click on [Movie Capture] at the start point you wish to capture a Motion image.
 - "Now capturing a movie" is displayed.
- 4** Click STOP to end capture.
 - "Now Searching..." is displayed.
 - The DV Tape is rewound to the point at which the capture was started. The Motion image is then transferred to the PC.
 - "Data transfer is now in progress" is displayed on the PC screen.
 - The maximum capture time is approx. 30 seconds. Capture stops automatically at the end of 30 seconds.

Note

- Motion images cannot be captured if data contains the following...
 - A change between 12 bit and 16 bit.
 - A change between SP and LP mode.
- During transfer to the PC, the Motion images will not be displayed on the PC screen.
- Transfer takes from about 30 to 50 seconds for every 1 second of the Motion image when using USB connection.

- 5** To capture other Motion images, repeat steps 3~4.

PHOTOVU/MPEG4 Movie Messenger™ System

Playing back the saved Motion and Still images

You can play back the saved Motion images and Still images (p. 60) for confirmation.

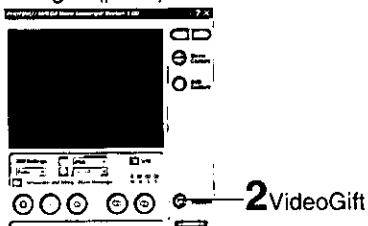

3 View Manager

4 All Picture

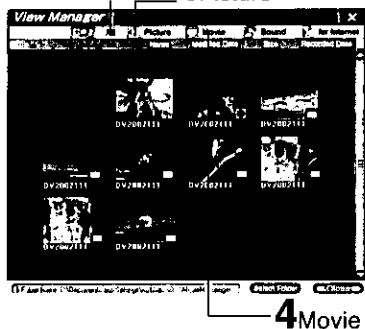

All:
Still image, Motion image and Sound data are displayed.

Picture:
Still image data (*.BMP, *.JPG) is displayed.

Movie:
Motion Image data (*.AVI, *.WMV) is displayed.

Sound:
Sound image data (*.WAV) is displayed.

For Internet:
The data (*.WMV, *.JPG) is displayed.

1 Repeat steps 1~4 on page 59 to run the PHOTOVU/MPEG4 Movie Messenger™ System.

2 Click [VideoGift] to display the VideoGift screen.
• The image captured last is displayed in the VideoGift screen.

Caution for Windows 2000 users

• If warning indication is displayed, please see page 86.

3 Click [View Manager] to display the View Manager screen.

To view Motion images

4 Click on [Movie].
• The first frame of each Motion image will be displayed as a list.

5 Double click on the desired Motion image to display the playback screen.
• Click ▶ to start Motion image playback.

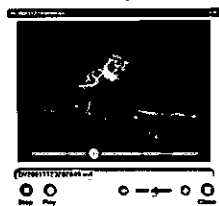

Note

• You can also playback a motion image by simply pointing at the thumbnail with your mouse. Duration, Rec Time, and size are displayed as well. (Only size for still images.)

To view Still images

4 Click on [All] or [Picture] to display the Still image list.

5 Double Click on the desired image to open it.



Note

• If the image cannot be opened, please refer to the software Help menu.

VideoGift Screen

You can use these features using the VideoGift Screen.

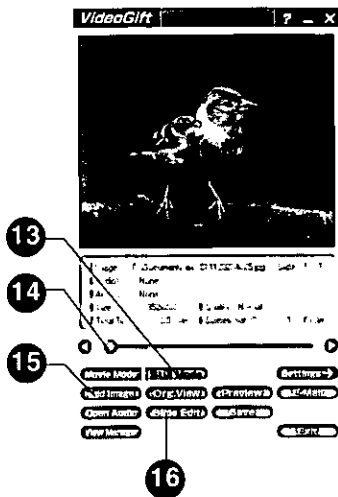
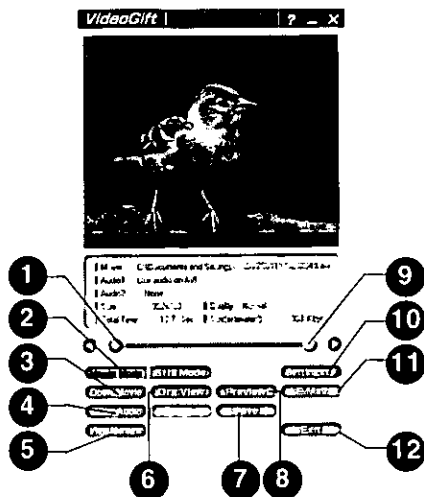

- 1 Slider**
Drag the pointer of the playback start position.
- 2 Movie Mode**
You can display motion images.
- 3 Open Movie**
You can open folders containing video files (*.AVI, *.WMV).
- 4 Open Audio**
You can open folders containing audio files (*.WAV). Valid only when the file is opened in the VideoGift screen.
- 5 View Manager**
You can open the View Manager screen.
- 6 Org. View**
You can play original moving image: (Uncompressed moving image.)
- 7 Save**
You can save the compressed images (*.WMV) to your hard disk.
- 8 Preview**
You can preview the compressed motion image.
- 9 Slider**
Drag the pointer of the playback end position.
- 10 Settings**
You can open the "Compression Settings" screen. (p. 67)
- 11 E-mail**
You can attach the compressed image to your e-mail.
- 12 Exit**
Exits VideoGift screen.
- 13 Still Mode**
You can display still images.
- 14 Slider**
When several still images are opened in the VideoGift screen, a slide show of the images can be done.
- 15 Add Image**
You can open the folder containing a desired still image to add images.
- 16 Slide Edit**
A collection of still images can be edited as a slide show.

Using the VideoGift Screen

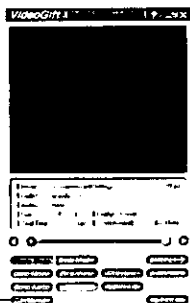
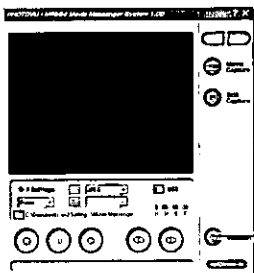

3 View Manager

4 All
4 Picture
4 Movie



5 Still Mode

5 Movie Mode

6 Open Movie

6 Add Image

1 Repeat steps 1~4 on page 59 to run the PHOTOVU/MPEG4 Movie Messenger™ System.

2 Click [VideoGift] to display the VideoGift screen.
• The image captured last is displayed in the VideoGift screen.

Caution for Windows 2000 users

• If warning indication is displayed, please see page 86.

3 Click [View Manager] to display the View Manager screen.

Using a Motion Image on the VideoGift Screen

4 Click on [Movie] to display a Motion image list on the View Manager screen.

5 Click on [Movie Mode] on the VideoGift screen.

6 Select the Motion image from the View Manager screen, then drag and drop the image to the "VideoGift" screen.

• By clicking [Open Movie], you can add the saved motion images on your PC hard disk. You can also select the file by dragging and dropping from Windows Explorer.

• You can use the VideoGift features (p. 62) on the VideoGift screen.

Using a Still Image on the VideoGift Screen

4 Click on [All] or [Picture] to display a Still image list on the View Manager screen.

5 Click on [Still Mode] on the VideoGift screen.

6 Select the Still image from the View Manager screen, then drag and drop the image to the "VideoGift" screen.

• When clicking [Add Image], you can add the saved still images on your PC hard disk.

• If selecting a frame from a motion image, See "Selecting a Frame from a Motion Image" on page 68.

• You can use the VideoGift features (p. 62) on the VideoGift screen.

Setting the Mail Software

It is possible to set the mail software to start up automatically when [E-Mail] of VideoGift is clicked.

Note

The e-mail Software must support MAPI (Messaging Application Programming Interface).

Below are some e-mail Software programs which support MAPI:

- Microsoft Outlook, Microsoft Outlook Express, Netscape Messenger;
- Outlook(R) Express 5x, Outlook97, Outlook98, Outlook2000
- Outlook Express 4x
- Other MAPI applications [Netscape(R) Messenger 4.5x, and so on]

- 1 Repeat steps 1~4 on page 59 to run the PHOTOVU/MPEG4 Movie Messenger™ System.
- 2 Click [VideoGift] to display the VideoGift screen.
 - The image captured last is displayed in the VideoGift screen.
- 3 Click [Settings] to display the Compression Settings/Mailer Settings screen.
- 4 Click ① to set the mail software.
 - The mail software installed in the computer will be displayed.
 - You can select Outlook Express or other software.

Caution for Windows 2000 users

- If warning indication is displayed, please see page 86.

Note

- If selecting software other than Outlook Express and Microsoft Outlook, click [Other]. From the file dialog box, select the executable file (*.exe) of the mail software application and then click [Open].

- 5 Click [Settings] to close the Compression Settings/Mailer Settings screen.

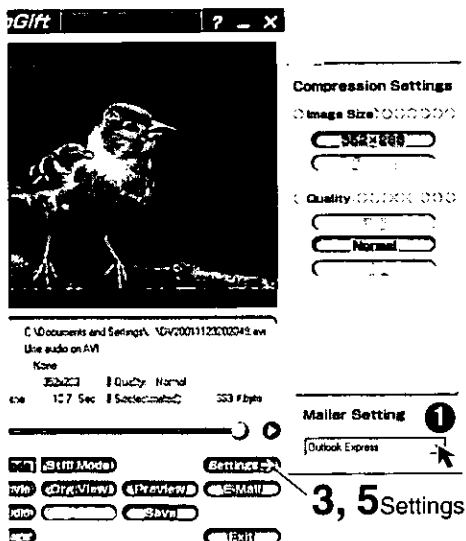

Attaching captured Motion and Still images to your e-mail

You can transfer and compress your Motion images as attachments to your e-mail easily.

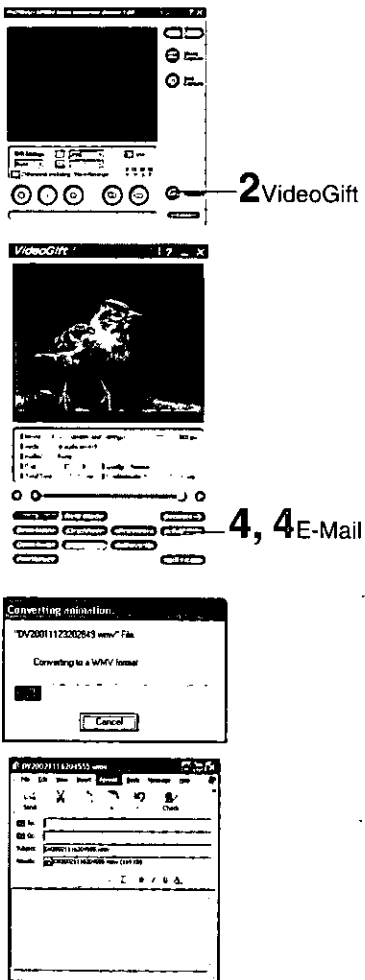

Before you begin

- Insert a recorded tape. (p. 10)
- Make Palmcorder-PC connections. (pp. 57, 58)
- Turn your PC on. (p. 57)
- Set Palmcorder POWER to VCR.

1 Repeat steps 1~4 on page 59 to run the PHOTOVU/MPEG4 Movie Messenger™ System.

2 Click [VideoGift] to display the VideoGift screen.
• The image captured last is displayed in the VideoGift screen.

Caution for Windows 2000 users

- If warning indication is displayed, please see page 86.

Attaching Motion images to e-mail

3 Repeat steps 4~6 on page 63 to select a Motion Image.
• If sending a portion of a Motion image, see "Sending a Portion of a Motion Image" on page 66.
• To compress a Motion image, see "Setting the Size and Quality of Motion and Still Image" on page 67.

4 Clicking on [E-Mail] will convert the selected image to WMV format.

Note

- Follow the instructions as they appear on your PC screen.

Attaching Still images to e-mail

3 Repeat steps 4~6 on page 63 to select a Still Image.
• To compress a Still image, see "Setting the Size and Quality of Motion and Still Image" on page 67.

4 Clicking on [E-Mail] will convert the selected image to WMV format.

Note

- Follow the instructions as they appear on your PC screen.

Note

- Refer to Help for information about application operations and Error messages.
- If your e-mail software is not supported by MAPI, pressing the [E-Mail] button will automatically open the folder containing the compressed file. To attach, drag and drop the file into your e-mail.

Sending a Portion of a Motion Image

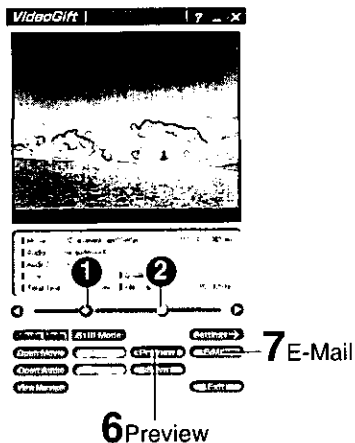

- 1 Repeat steps 1-4 on page 59 to run the PHOTOVU/MPEG4 Movie Messenger™ System.
- 2 Click [VideoGift] to display the VideoGift screen.
 - The image captured last is displayed in the VideoGift screen.
- Caution for Windows 2000 users**
 - If warning indication is displayed, please see page 86.
- 3 Select a Motion image. (Continue with steps 4-6 on page 63 to specify the portion to be played.)
- 4 Drag pointer ① to start position.
- 5 Drag pointer ② to end position.
- 6 Click [Preview]. (To set size/quality, do steps 4 and 5 on page 67.)
 - To save the image to your PC, click [Save].
- 7 Click [E-Mail] and then send the e-mail message. (p. 65)

Slide-Show Edit

A collection of still images can be edited as slides.

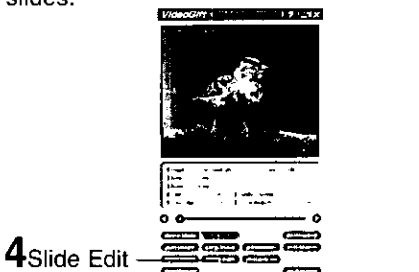

- 1 Repeat steps 1-4 on page 59 to run the PHOTOVU/MPEG4 Movie Messenger™ System.
- 2 Click [VideoGift] to display the VideoGift screen.
 - The image captured last is displayed in the VideoGift screen.
- Caution for Windows 2000 users**
 - If warning indication is displayed, please see page 86.
- 3 Select the Still images. (See steps 4-6 on page 63.)
 - The selected Still images are displayed on the VideoGift screen.
- 4 Click on [Slide Edit] on the VideoGift screen.
 - The "Slide-show Edit" screen is displayed.
- 5 Edit slides.
 - Use "Help" for detailed instructions.

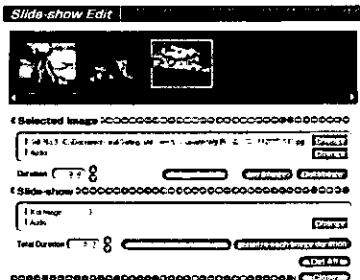

Setting the Size and Quality of Motion and Still Image

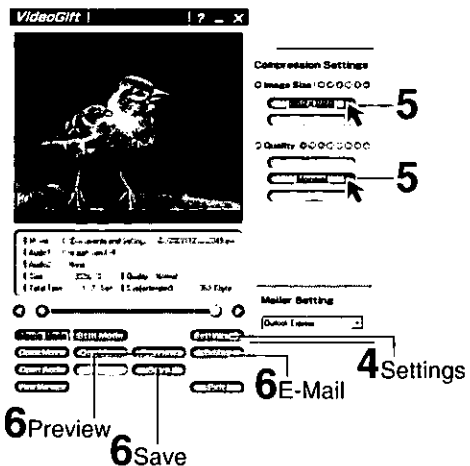

Size of Compressed File

Image Quality	Image Size	
	352 x 288 pixels	176 x 144 pixels
High	3000 KB/min	1000 KB/min
Normal	2000 KB/min	600 KB/min
Low	1000 KB/min	360 KB/min

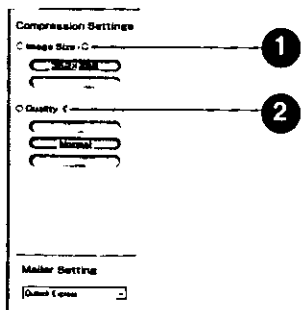

- 1 Repeat steps 1~4 on page 59 to run the PHOTOVU/MPEG4 Movie Messenger™ System.
- 2 Click [VideoGift] to display the VideoGift screen.
 - The image captured last is displayed in the VideoGift screen.

Caution for Windows 2000 users

- If warning indication is displayed, please see page 86.

- 3 Select a Motion or Still image. (See steps 4-6 or 4-6 on page 63.)
 - The selected Motion or Still image is displayed on the VideoGift screen.
- 4 Press [Settings] to display the "Compression Settings" screen.
- 5 Set the Image Size and Quality.
 - See "Size of Compressed File" to the left.
- 6 Click [Save] to save the compressed image to your PC.
 - Click [Preview] to view the compressed Motion Image.
 - Click [E-mail] to send the e-mail message.

- 1 Image Size
You can select the image size (352 x 288 or 176 x 144).
- 2 Quality
You can select the image quality (High, Normal, Low).

PHOTOVU/MPEG4 Movie Messenger™ System

Selecting a Frame from a Motion Image

This screen is displayed when an individual frame from a moving image file is to be added as a still image.

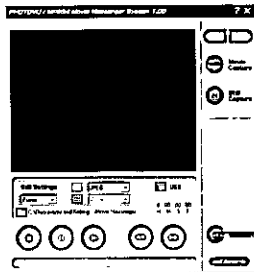

2 VideoGift

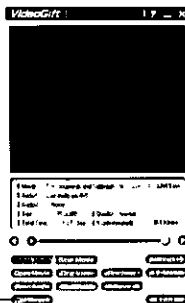

3 View Manager

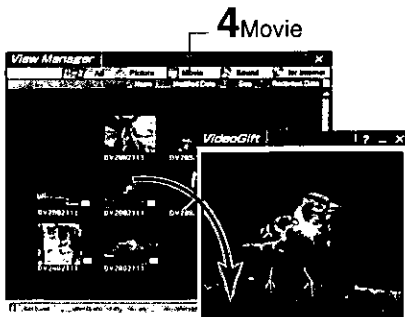

4 Movie

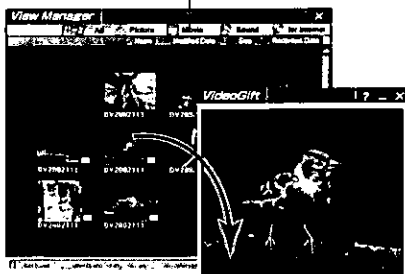

5 Still Mode

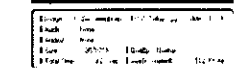

9 Preview

9 Save



9 E-Mail

1 Repeat steps 1-4 on page 59 to run the PHOTOVU/MPEG4 Movie Messenger™ System.

2 Click [VideoGift] to display the VideoGift screen.
• The image captured last is displayed in the VideoGift screen.

Caution for Windows 2000 users

• If warning indication is displayed, please see page 86.

3 Click [View Manager] to display the View Manager screen.

4 Click on [Movie] to display a Motion image list on the View Manager screen.

5 Click on [Still Mode] on the VideoGift screen.

6 Select the Motion image from the View Manager screen, then drag and drop the image to the "VideoGift" screen.
• The "Select Frame" screen is displayed.

7 Drag the pointer ① to select a desired frame.

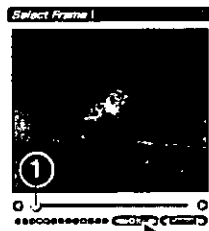

8 Click [OK].

9 Click [Save] to save the compressed image to your PC.

Click [Preview] to view the compressed Motion Image.

Click [E-mail] to send the e-mail message.

Transferring Your Images (i.LINK) (Windows)

PC Connection with DV Interface Cable (i.LINK)

A video clip can be transferred directly to your PC (Personal Computer) via a DV Interface Cable (i.LINK) (not supplied) using products and software from a number of editing software companies including Canopus and Pinnacle.

Using products from these companies allows you to capture and edit video clips using the DV interface (i.LINK).

For more detailed information regarding editing software products from these companies, please visit their websites at:

www.justedit.com

www.pinnaclesys.com

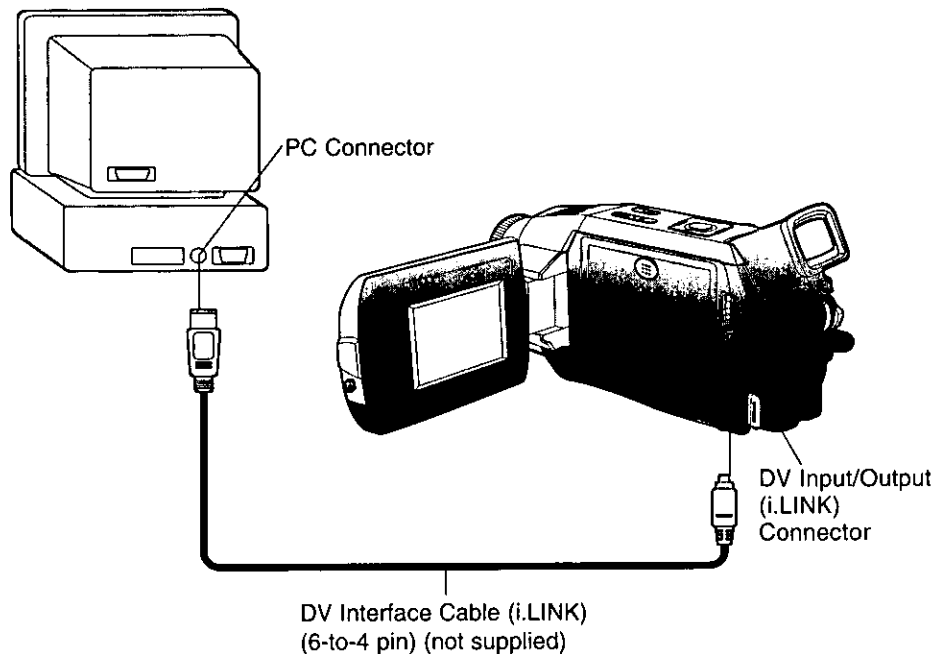

WPC Connection

Note

- PC must be equipped with an i.LINK terminal.
- During Palmcorder playback, do not disconnect the DV Interface Cable (i.LINK) or turn the Palmcorder off as this may cause a PC hang-up error.
- For PHOTOVU/MPEG4 Movie Messenger™ System, do not use 2 i.LINK terminals on your PC at the same time.
- PHOTOVU/MPEG4 Movie Messenger™ System i.LINK (DV) operates normally with Windows 98SE or later operating system.
- PHOTOVU/MPEG4 Movie Messenger™ System i.LINK connection may not work with some DV Interface boards. In this case, use the software included with the board.
- 1394 (i.LINK) interface must conform to OHCI (Open Host Controller Interface Specification).

Using Tape Image Data

By connecting the Palmcorder and PC with the DV Interface Cable (i.LINK), you can transfer Motion images and still images saved on the DV Tape directly to your PC.

Note

- If PHOTOVU/MPEG4 Movie Messenger™ System does not work, please refer to note on page 69.
- Deactivate your PC ScreenSaver or this application may shutdown during image capture.

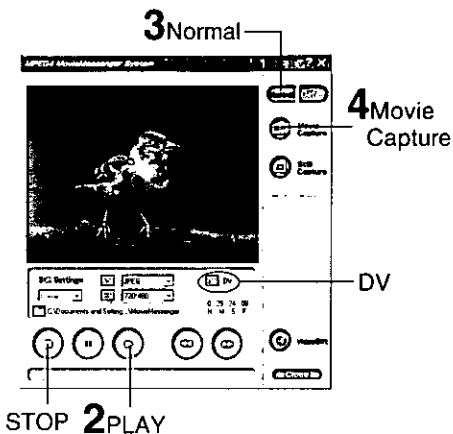

Before you begin

- Insert a recorded Tape. (p. 10)
- Make Palmcorder-PC connections. (p. 69)
- Turn your PC on.
- Set Palmcorder POWER to VCR.
- Run the Software after the DV Interface Cable (i.LINK) has been connected to the Palmcorder.

- 1 Repeat steps 1-4 on page 59 to run the PHOTOVU/MPEG4 Movie Messenger™ System.

Note

- When the DV Interface Cable (i.LINK) is connected, the input display will automatically become DV. If it is not DV, please confirm the connection. Then, close and restart the software.
- When using Windows XP, "Windows Movie Maker" may open automatically. If so, close "Windows Movie Maker" and "Movie Messenger", and open "Movie Messenger" again.

- 2 Click ► (PLAY) button on PC screen to playback the DV tape.
 - Please use the LCD monitor on the Palmcorder or PC screen for confirmation.

To capture Motion images

[When selecting Normal]

- 3 Click on [Normal].
- 4 Click on [Movie Capture] at the point you wish to capture a Motion image. Click on [STOP] to end capture.
 - The image is transferred to the PC in real time.
 - The maximum capture time is approx. 3 minutes.
 - When capturing data containing changes between 12 bit and 16 bit and/or between SP and LP mode, a separate file will be made for each mode.
 - Please refer to pages 60-68 for other functions.

(Continued on next page.)

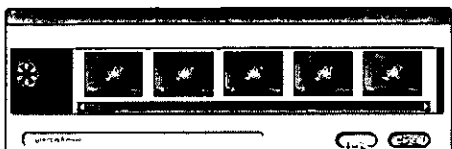
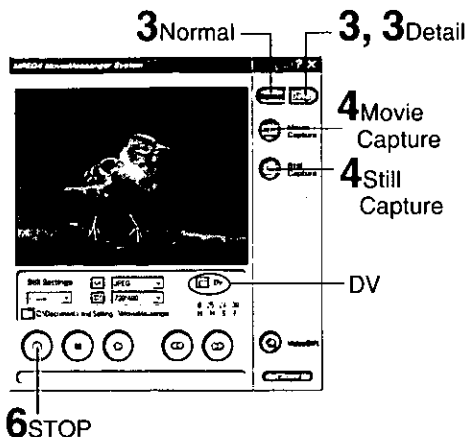

To capture Still images

[When selecting Detail]

- 3** Click on [Detail].
- 4** Click on [Still Capture] at the point you wish to capture images.
 - The screen to select frames is displayed.
- 5** Select the frame for the segment to be captured select frames, and click [Select].
 - Repeat steps 4 and 5 to continue capturing images.
 - Captured Still images are saved to the PC, and you can playback the saved images on the View Manager. (P. 61)

[When selecting Detail]

Note

- Detail mode lets you specify the start and end frames for the video segment you want to capture and save.

- 3** Click on [Detail].
- 4** Click on [Movie Capture] at the point you wish to capture a Motion image.
 - The screen to select the start frame is displayed.
- 5** Select the start frame for the segment to be captured select one frame, and click [Select].
 - "Now Searching..." is displayed, and the DV tape is rewound to the point at which the capture was started.
 - "Now capturing a movie." is displayed.
- 6** Click on [Stop] to end capture.
 - The screen to select the end frame is displayed.
- 7** Select the end frame for the segment to be captured select one frame, and click [Select].
 - "Saving a file..." is displayed.
 - The image is transferred to the PC in real time.

To capture Still images

[When selecting Normal]

- 3** Click on [Normal].
- 4** Click on [Still Capture] at the point you wish to capture an image.
 - Repeat step 4 to continue capturing images.
 - Captured Still images are saved to the PC, and you can playback the saved images on the View Manager. (P. 61)

Palmcorder USB Device Driver/SD Drive

Connection (for Palmcorder USB Device Driver/SD Drive)

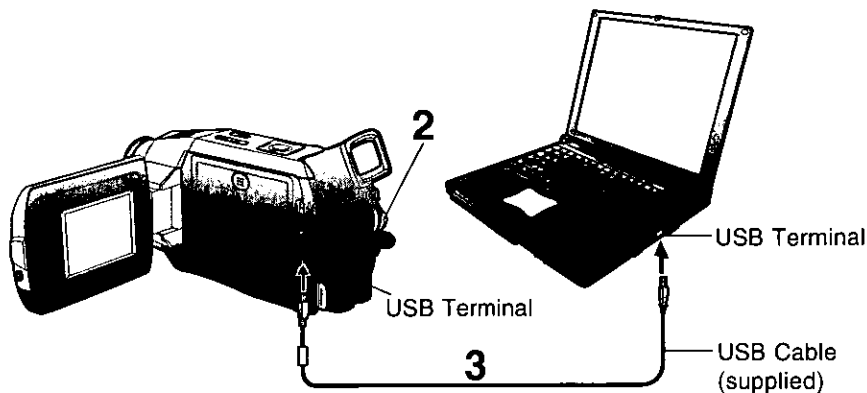

1 Turn on your PC.

2 Set the Palmcorder POWER to M-CARD.

For Windows XP users

3 Connect the Palmcorder to your PC (Windows) using the USB Cable (supplied).

- "CONNECT WITH PC" appears in the EVF or the LCD monitor.
- The "Found New Hardware Wizard" screen of Windows is displayed.

The following message **2** is displayed. Even so, functionality confirmation has been performed at our manufacturer.

Click [Continue Anyway] and proceed.

Follow the instructions as they appear on your PC screen.

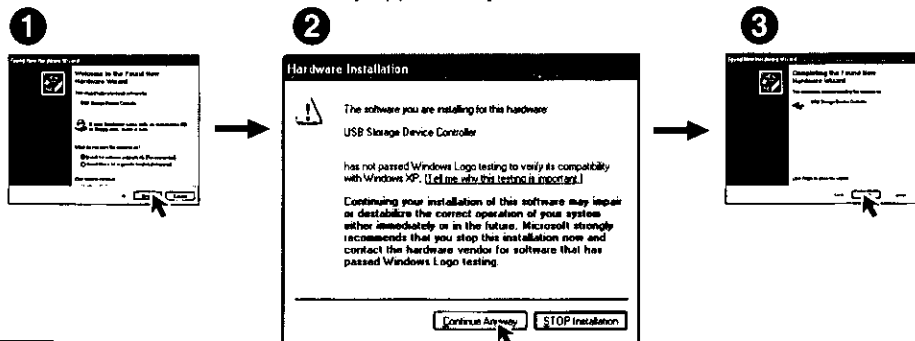

Note

- When connecting for the first time using Windows XP, the OS installation CD may be required.
- Follow the instructions as they appear on your PC screen.
- For extended use, the AC Adaptor should be used as a power source.

Palmcorder USB Device Driver/SD Drive

For Windows 2000 users

- 3** Connect the Palmcorder to your PC (Windows) using the USB Cable (supplied).
- “CONNECT WITH PC” appears in the EVF or the LCD monitor.
 - The “Found New Hardware” screen of Windows is displayed.
 - When the Palmcorder and PC (with Windows 2000) are connected via USB, a message, such as the one below, is displayed.
- The following message is displayed. Even so, functionality confirmation has been performed at our manufacturer. Click [Yes] and proceed.

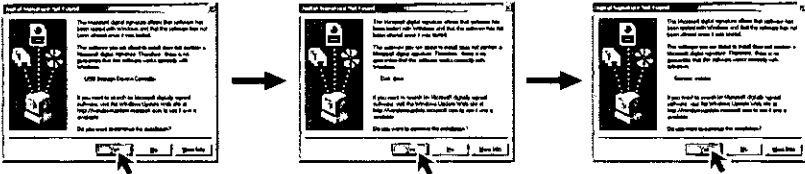

Note

- For extended use, the AC Adaptor should be used as a power source.

For Windows 98SE/Me users

- 3** Connect the Palmcorder to your PC (Windows) using the USB Cable (supplied).
- “CONNECT WITH PC” appears in the EVF or the LCD monitor.

Note

- For extended use, the AC Adaptor should be used as a power source.

Using Memory Card Image Data

By connecting the Palmcorder and PC with the USB, you can transfer Still images saved on the Memory Card directly to your PC.

Before you begin

- Install the Palmcorder USB Device Driver. (p. 55)
- Set POWER to OFF before inserting a recorded Memory Card. (pp. 47, 48)
- Make Palmcorder-PC connections. (pp. 72, 73)
- Turn your PC on. (p. 72)

For Windows 98SE/Me/2000 users

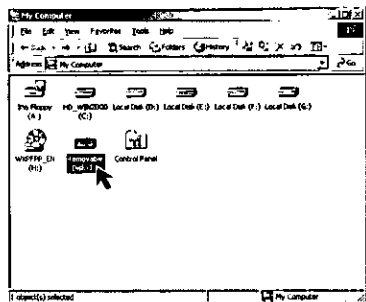

1 Connect the Palmcorder to your PC using the USB Cable (supplied). (pp. 72, 73)

- "PLEASE WAIT", "CONNECT WITH PC", and "STORAGE" appears in the EVF or the LCD monitor.

2 Open My Computer.

3 Click [Removable Disk].

- You can view images stored on the Memory Card and also save them to your hard disk.

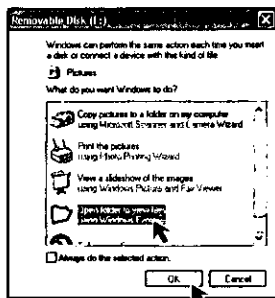

For Windows XP users

1 Connect the Palmcorder to your PC using the USB Cable (supplied). (pp. 72, 73)

- The "Removable Disk" screen is displayed.
- "PLEASE WAIT", "CONNECT WITH PC", and "STORAGE" appears in the EVF or the LCD monitor.

2 Click on [Open folder to view files using Windows Explorer] and then [OK].

- You can view images stored on the Memory Card and also save them to your hard disk.

Note

- Please do not change file or folder names on the PC. The images on the Memory Card may not be able to be viewed on the Palmcorder.
- When "ACCESS" is displayed in the EVF or LCD monitor, please do not remove the Memory Card or USB Cable, or turn off the power as data may be damaged.

Palmcorder File Converter

Using Palmcorder File Converter

You can convert the JPEG data of your PC into DCF (Design rule for Camera File System) data, and transfer this data to your Palmcorder via USB.

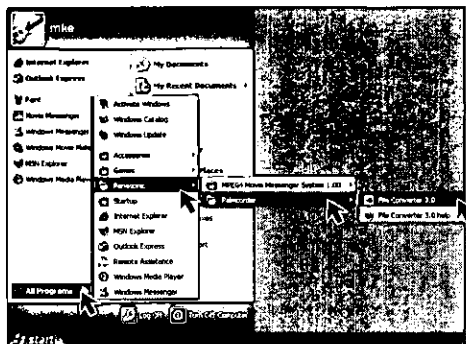

- 1 Set Palmcorder POWER to M-CARD.
- 2 Connect the Palmcorder to your PC using the USB Cable (supplied). (pp. 57, 58)
- 3 Click on "Start," "(All) Programs," "Panasonic," "Palmcorder," then "File Converter 3.0."
- 4 Select and click "To resize the image" or "To convert format for Panasonic Digital Palmcorder."

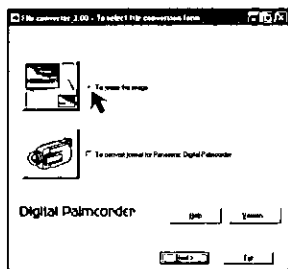

To resize the image:

The size of images captured with the Palmcorder can be increased or decreased to make them suitable for Internet and E-mail use.

To convert format for Panasonic Digital Palmcorder:

Images can be converted to JPEG format and to file names that can be played back on the Palmcorder.

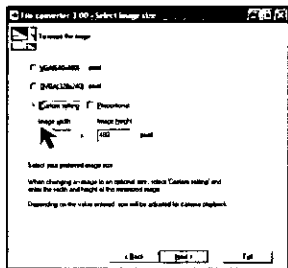

When selecting "To resize the image"

- 5 Select the size for the image you want to change. Then, click on "File select" and select the file to be converted.

Note

- When User Select is selected, you can specify a size within a range of 2,048 x 1,536 ~ 64 x 48 pixels.

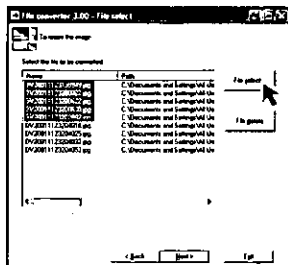

(Continued on next page.)

Palmcorder File Converter

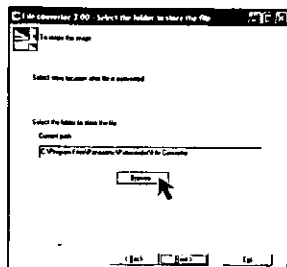

- 6** Select the folder to which the converted file is to be saved.
- The Conversion results screen is displayed.

- 7** Use "Help" for detailed instructions.

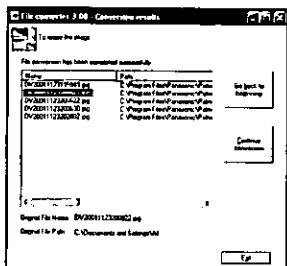

When selecting "To convert format for Panasonic Digital Palmcorder"

- 5** Select the file to be converted.

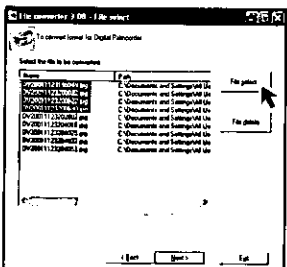

- 6** Select the drive to which the converted file is to be saved.
- The Conversion results screen is displayed.

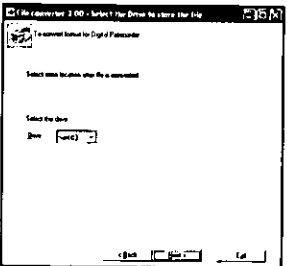

- 7** Use "Help" for detailed instructions.

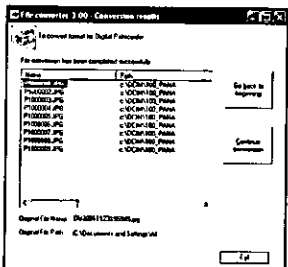

Before Using Web Camera* Features

Web Camera*

MSN Messenger and NetMeeting are software that can be linked and used together. Using the Palmcorder and the internet, you can communicate with others by having picture and sound similar in fashion to a videophone.

Please read this first

- To use the Web Camera feature, Microsoft's Windows Messenger, MSN Messenger Service, and Windows NetMeeting are required.
- For this feature, both parties must have Windows XP.
- For this feature, both parties must have Windows 98SE/Me/2000.

- MSN Messenger Service, Windows Messenger and Windows NetMeeting are registered trademarks of America Microsoft Corporation in the United States and other countries.
- Communication quality and assured connectability are dependent upon the congestion conditions of your internet provider and MSN Messenger Service, etc. This product does not guarantee assured communication quality.

Conditions for Use

- You have direct dial-up connection capability to the internet. Also, you and the other person(s) are in the same Network (LAN).
- Microsoft MSN Messenger Service 4.5 or newer/Windows NetMeeting 3.01 or newer is installed.
For Windows xp users, Windows Messenger 4.5 or newer is installed.
- It is convenient if the person you want to access is already a registered member of Windows Messenger or MSN Messenger Service.

For Windows XP users

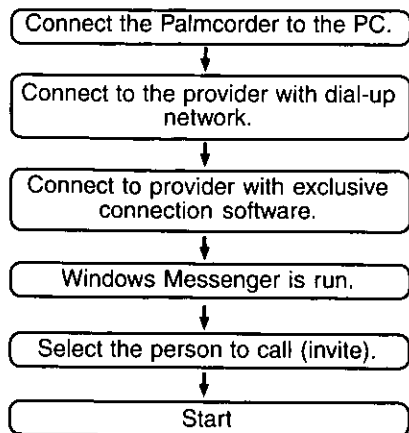

For Windows 98SE/Me/2000 users

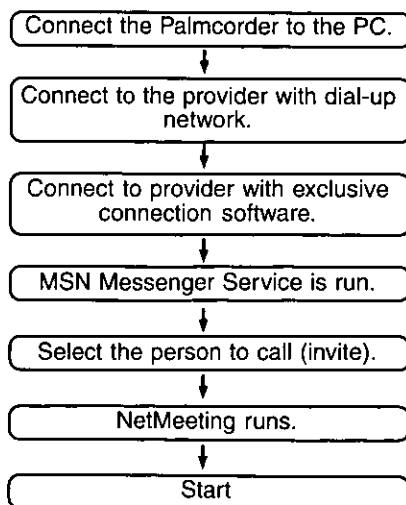

Web Camera

Connection (for Web Camera)

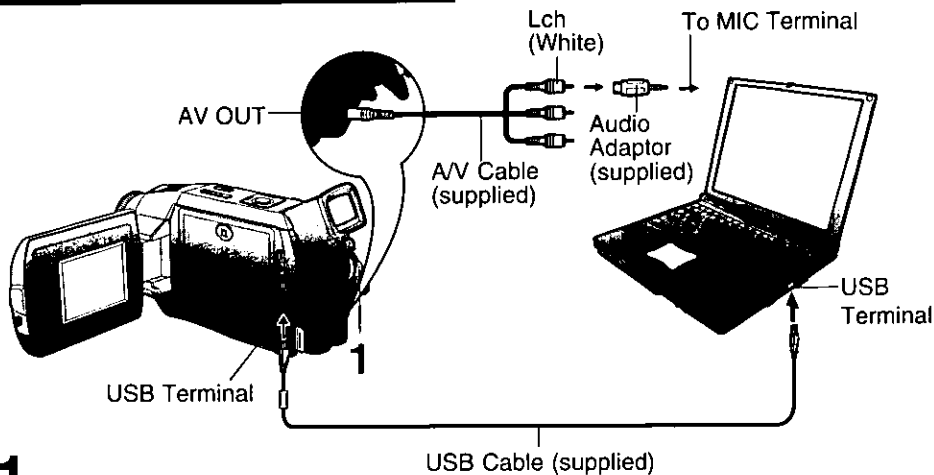

- 1 Turn on your PC.
- 2 Set the Palmcorder POWER to CAMERA.

For Windows XP users

- 3 Connect the Palmcorder to your PC (Windows) using the USB Cable (supplied).
 - "Found New Hardware Wizard" is displayed.
 - The following message ② is displayed. Even so, functionality confirmation has been performed at our manufacturer.
 - Click [Continue Anyway] and proceed.
 - Follow the instructions as they appear on your PC screen.

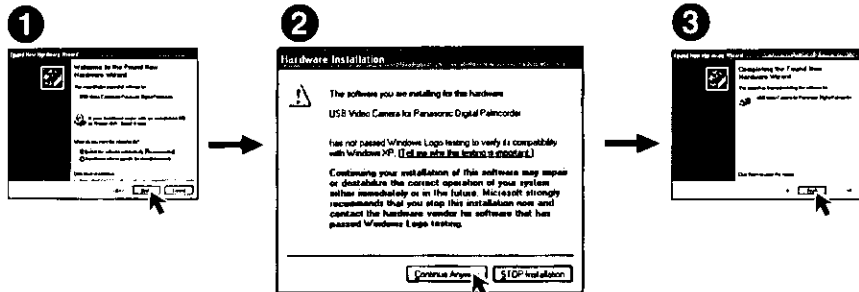

- "CONNECT WITH PC" and "WEB CAM" are displayed in the EVF and LCD monitor. A gray box is also displayed. The image within the box can be used with communication.
- Place the Palmcorder so that you are in the picture.
- To confirm if the connection between the Palmcorder and PC is correct, please refer to "Tuning Wizard" on page 81.

Note

- When connecting for the first time using Windows XP, the OS installation CD may be required. Follow the instructions as they appear on your PC screen.

- 4 Go to step 5 on page 79.

For Windows 2000 users

- 3** Connect the **Palmcorder to your PC (Windows)** using the USB Cable (supplied).
- "Found New Hardware" is displayed.
 - "CONNECT WITH PC" and "WEB CAM" are displayed in the EVF and LCD monitor. A gray box is also displayed. The image within the box can be used with communication.
 - Place the Palmcorder so that you are in the picture.
 - To confirm if the connection between the Palmcorder and PC is correct, please refer to "Tuning Wizard" on page 81.
 - When the Palmcorder and PC (with Windows 2000) are connected via USB, a message, such as the one below, is displayed.
- The following message is displayed.**
Even so, functionality confirmation has been performed at our manufacturer.
Click [Yes] and proceed.

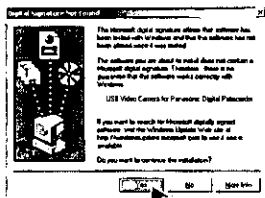

- 4** Go to step 5 below.

For Windows 98SE/Me users

- 3** Connect the **Palmcorder to your PC (Windows)** using the USB Cable (supplied).
- "CONNECT WITH PC" and "WEB CAM" are displayed in the EVF and LCD monitor. A gray box is also displayed. The image within the box can be used with communication.
 - Place the Palmcorder so that you are in the picture.
 - To confirm if the connection between the Palmcorder and PC is correct, please refer to "Tuning Wizard" on page 81.

Note

- When connecting for the first time using Windows 98SE or Me, the OS installation CD may be required.

- 4** Go to step 5 below.

- 5** Connect the **A/V Cable (supplied) to the Audio Adaptor (supplied).**
- For PCs with no built-in mic, connecting the A/V Cable (supplied) to the Audio Adaptor (supplied), the Palmcorder replaces the mic.
 - If the speaker and mic are in close proximity, howling may occur.

Note

- Do not disconnect the USB Cable while in use. This could be a source of trouble. For more details, please read the respective Help file.

Web Camera (For Windows XP users)

For Windows Messenger (Windows XP only)

When Windows Messenger is newly installed or when run the first time, the following settings become necessary. For more details, please read the respective Help file.

Note

- Once settings are performed, they are not required from the second time the software is run.

Before you begin

- Be sure you have a dial-up connection.
- Referring to pages 78-79, connect the Palmcorder and PC.
Confirm that equipment is connected correctly by running the [Audio Tuning Wizard]. (p. 81)

Caution

- This feature can be used only if both parties have Windows XP.
For Windows Messenger, please refer to the Microsoft Home Page:
<http://www.microsoft.com/>
<http://www.msn.com/>

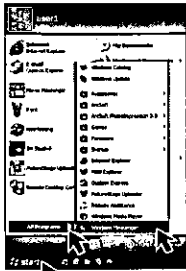

- 1 Turn on your PC.
- 2 Click on "Start," "All programs," "Windows Messenger."
 - "Windows Messenger" screen is opened.
- 3 Click on [About Windows Messenger] in the [Help] menu.

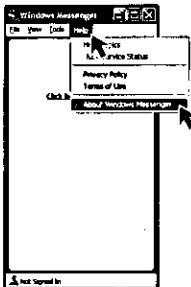

Note

- Confirm that your version is 4.5 or newer.
- If you have a version older than 4.5, please download the latest version (4.5 or newer) from the Microsoft Home Page:
<http://www.microsoft.com/>
<http://www.msn.com/>
- For download and installation instructions, please refer to Help on the Home Page.

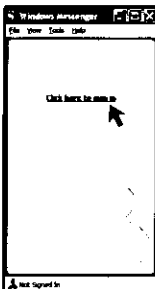

- 4 The first time Windows Messenger is run, etc., the Setup screen is displayed.
Click [Click here to sign in].
Please carefully read the contents and then proceed.

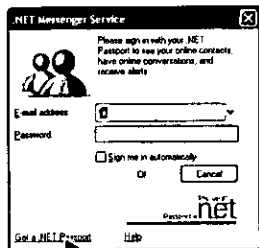

5 Type in your E-mail address and password.

- You'll need to get a hotmail address. If you do not have one, click on [Get a .NET Passport]. Please carefully read the displayed contents and then proceed.

There are times when a Version Upgrade screen will be displayed. However, if you are using Windows Messenger 4.5 or newer, there is no need to upgrade.

6 Click on [Audio Tuning Wizard] in the [Tools] menu.

Note

- You can set the volume for playback or mic volume, etc.
- Also, confirm that the Palmcorder and PC are connected correctly.

The person you wish to access needs to do settings 1~6 also.

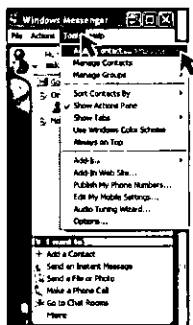

7 Select [File] -> [Add a Contact] to register the person you wish to access in Windows Messenger.

- Please enter the same e-mail address that the other person has registered with Windows Messenger.
- After registering the e-mail address of the person you wish to access, click on [Send E-Mail] and have the person register your e-mail address as well.

You cannot call a person who is not signed-on to Windows Messenger.

Web Camera (For Windows XP users)

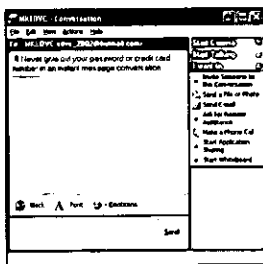
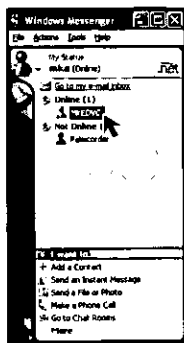

8 The person calling (inviting) side

Double-click a person to call from those currently [on-line].

- "xxx-conversation" screen is displayed.

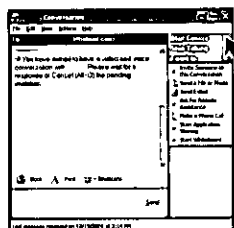

9 The person calling (inviting) side

Click [Start Camera] in the "xxx-conversation" screen.

- A message inviting the other person is displayed.

The invited person side

A message asking if the person accepts or declines is displayed.

Click [Accept] on the screen.

- To ignore the invitation, click [Decline].

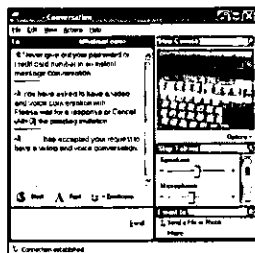

10 At this point you may proceed with a voice/video conversation.

Note

- For other information about Windows Messenger, please refer to Help.

11 When access is finished, close Windows Messenger, then set Palmcorder POWER to OFF. Finally, disconnect the USB Cable.

For MSN Messenger Service and Windows NetMeeting (Windows 98SE/Me/2000)

When MSN Messenger Service is newly installed or when run the first time, the following settings become necessary. For more details, please read the respective Help file.

Note

- Once settings are performed, they are not required from the second time the software is run.

Before you begin

- Be sure you have a dial-up connection.
- Referring to pages 78~79, connect the Palmcorder and PC.
Confirm that equipment is connected correctly by running the [Audio Tuning Wizard]. (p. 84)

Caution

- For MSN Messenger Service and Windows NetMeeting, please refer to the Microsoft Home Page:
<http://www.microsoft.com/>
<http://www.msn.com/>

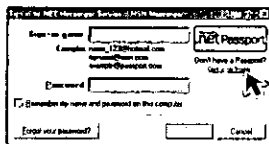
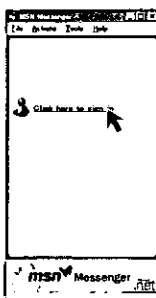

- 1 Turn on your PC.
- 2 Download the latest version MSN Messenger Service (4.5 or newer) and Windows NetMeeting (3.01 or newer) from the Microsoft Home Page:
<http://www.microsoft.com/>
<http://www.msn.com/>
 - For download instructions, please refer to Help on the Home Page.
- 3 Install the MSN Messenger Service.
- 4 Follow the instructions on the screen.
The first time MSN Messenger Service is run, etc., the Setup screen is displayed.
Click [Click here to sign in]. Please carefully read the contents and then proceed.
- 5 Type in your Sign-in name and password.
 - You'll need to get a hotmail address. If you do not have one, click on [Get one here]. Please carefully read the displayed contents and then proceed.

There are times when a Version Upgrade screen will be displayed. However, if you are using MSN Messenger Service 4.5 or newer, there is no need to upgrade.

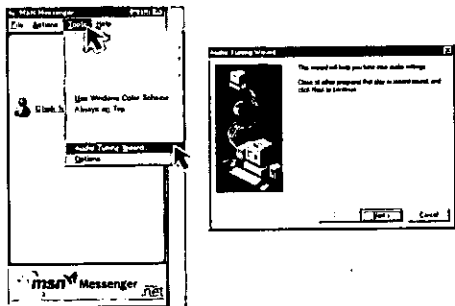

6 Click on [Audio Tuning Wizard] in the [Tools] menu.

Note

- You can set the volume for playback or mic volume, etc.
- Also, confirm that the Palmcorder and PC are connected correctly.

The person you wish to access needs to do settings 1~6 also.

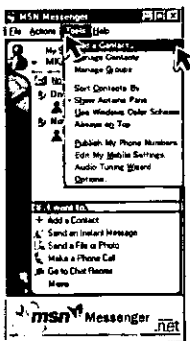

7 Select [Tools] -> [Add a Contact] to register the person you wish to access in MSN Messenger Service.

- Please enter the same e-mail address that the other person has registered with MSN Messenger Service.
- After registering the e-mail address of the person you wish to access, click on [Send E-Mail] and have the person register your e-mail address as well.

You cannot call a person who is not signed-on to MSN Messenger Service.

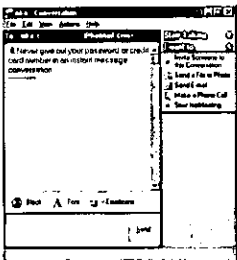
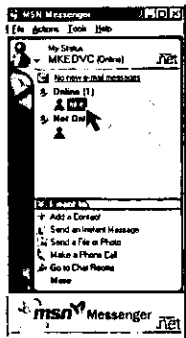

8 The person calling (inviting) side

Double-click a person to call from those currently [on-line].

- "xxxx-conversation" screen is displayed.

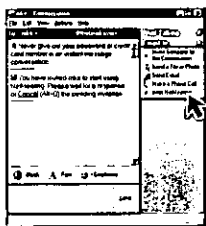

9 The person calling (inviting) side

Click **[Start NetMeeting]** in the "xxx-conversation" screen.

The invited person side

The Instant Message screen appears and a confirmation message is displayed. Click on **[Accept]**.

The **NetMeeting** screen is automatically opened.

Note

The first time Windows NetMeeting is run, etc., the Setup screen is displayed. Please carefully read the contents and then proceed.

The **user information, etc. is input.** Following the directions, please complete the settings.

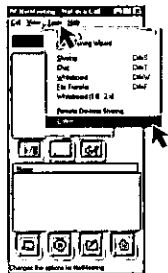

10 Click on **[Options]** in the **[Tools]** menu to confirm Video Camera Properties.

- If Video is not recognized in Video Camera Properties, select Control Panel, System, Device Manager, and finally Image Device for confirmation.

11 The invited person side

A message asking if the person accepts or declines is displayed. Click **[Accept]** on the screen.

- To ignore the invitation, click **[Decline]**.

12 The person calling (inviting) side

"Incoming-Call" screen is displayed. Click on **[Accept]**.

13 The invited person side The person calling (inviting) side

The real-time live picture displayed in the video camera is displayed on both yours and the other person's window screen.

Note

- If the picture is not displayed, click **[F7]** several times on the screen.
- For other information about MSN Messenger Service and Windows NetMeeting, please refer to Help.

14 When access is finished, close MSN Messenger Service and Windows NetMeeting, then set Palmcorder POWER to OFF. Finally, disconnect the USB Cable.

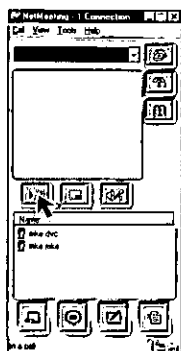
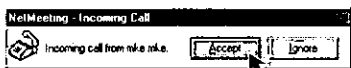
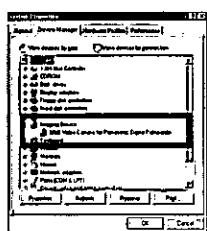
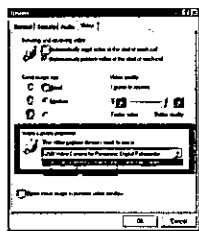

Warning Indications

Windows 2000

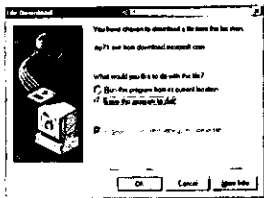
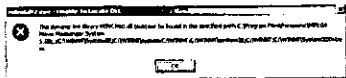

In Windows 2000, startup PHOTOVU/ MPEG4 Movie Messenger™ System. Clicking on [VideoGift] may cause the following type of error to occur. If so, please perform the following instructions.

Download and install Media Player (7.1 or newer), go to <http://www.microsoft.com/windows/mediaplayer> (current as of Dec. 28, 2001).

- “Windows Media. com: Download” is opened.

Click [Download Now!] on the screen.

- The “File Download” screen is displayed. Then, follow the instructions on the screen.

Transferring Your Images (Macintosh)

You can transfer images from your Palmcorder tape to your Macintosh.

System Requirements (for Built-in SD Drive)

- Mac OS 9.0~9.1
- iMac, iBook or Power Macintosh® G3 with USB port or Power Mac™ G4
- RAM: 64 MB or more
- CD-ROM drive (for installation)
- USB Port
- Mouse or other pointing device

* Even if system requirements are met, there is no guarantee that the included software will work on all personal computers.

Connection

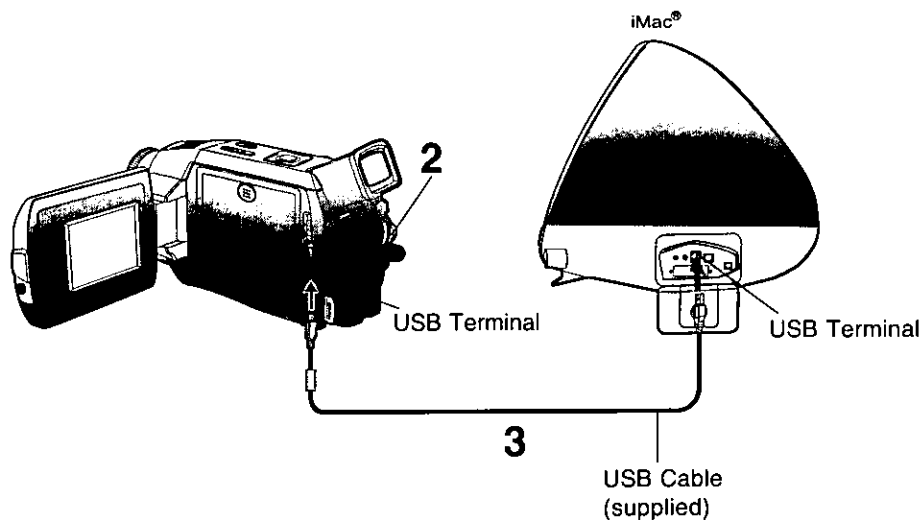

1 Turn on your PC.

2 Set the Palmcorder POWER to M-CARD.

3 Connect the Palmcorder to your Macintosh using the USB Cable (supplied).

Note

- For extended use, it is recommended to use the AC Adaptor as a power source.

Transferring Your Images (Macintosh)

Using Built-in SD Drive

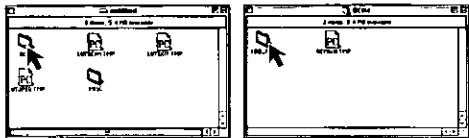

Before you begin











- Set POWER to OFF before inserting a recorded Memory Card. (pp. 47, 48)

- 1** Set the Palmcorder POWER to M-CARD.
- 2** Connect the Palmcorder to your Macintosh using the USB Cable (supplied). (p. 87)
 - "PLEASE WAIT", "CONNECT WITH PC", and "STORAGE" is displayed on the LCD monitor.
- 3** Double click the "Untitled" icon.
 - You can view images stored on the Memory Card and also save them to your hard disk.
- 4** Follow the instructions as they appear on your Macintosh section screen.

Note

- Please do not change file or folder names on the PC. The images on the Memory Card may not be able to be viewed on the Palmcorder.
- When "ACCESS" is displayed in the EVF or LCD monitor, please do not remove the Memory Card or USB Cable, or turn off the power as data may be damaged.

Palmcorder Accessory System

Accessory #	Figure	Description	Price
PV-DAC11A		AC Adaptor with AC Cable and DC Cable	Call For Pricing
CGR-D08A/1B		800mAh / 1 h 30 min, Battery Pack	\$69.95
CGR-D16A/1B		1 600mAh / 3 h, Battery Pack	\$99.95
CGP-D28A/1B		2 800mAh/ 5 h, Battery Pack	\$129.95
CGR-D53A/1K		5 300mAh / 9 h, Battery Pack	\$229.95
PV-DDC9		DV Interface Cable (i.LINK) (4-pin to 4-pin)	\$55.00
PV-DRC9		IR Remote Control	\$29.95
PV-H150		Carrying Case	\$49.95
RP-SD064BPPA RP-SD032BPPA RP-SD016BPPA		64 MB SD Memory Card 32 MB SD Memory Card 16 MB SD Memory Card	Call For Pricing
BN-SDCAPE/1B		SD USB Reader/Writer (compatible with MultiMediaCard)	\$79.95
BN-SDABPE/1B		SD PCMCIA Adaptor (compatible with MultiMediaCard)	\$79.95

For Your Information

Palmcorder Accessory Order Form

Please photocopy this form when placing an order.

1. Palmcorder Model # _____

2. Items Ordered

Accessory #	Description	Price Each	Quantity	Total Price
Subtotal				
Your State & Local Sales Tax				
Shipping & Handling				6.95
Total Enclosed				

3. Method of payment (check one)

- Check of Money Order enclosed (NO C.O.D.SHIPMENTS)
- VISA Credit Card # _____
- MasterCard Expiration Date _____
- Discover Customer Signature _____

Make Check or Money Order to: PANASONIC ACCESSORIES

(Please do not send cash)

4. Shipping information (UPS delivery requires complete street address)

Ship To:

Mr.

Mrs.

Ms. _____

First

Last

Phone #:

Day () _____

Street Address _____

Night () _____

City

State

Zip

TO OBTAIN ANY OF OUR PALMCORDER ACCESSORIES YOU CAN DO ANY OF THE FOLLOWING:

VISIT YOUR LOCAL PANASONIC DEALER

OR

CALL PANASONIC'S ACCESSORY ORDER LINE AT 1-800-332-5368

[6 AM-5 PM M-F, 6 AM-10:30 AM SAT, PACIFIC TIME]

OR

MAIL THIS ORDER TO: PANASONIC SERVICES COMPANY ACCESSORY ORDER OFFICE

20421 84th Avenue South Kent, WA. 98032

Notes On Operations

Replacing the Bulb

- 1** Insert a rigid wire, such as an extended paper clip into point (A) and lift cover up.

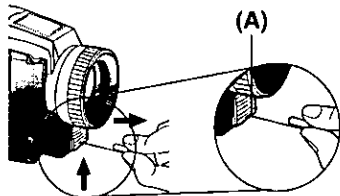

- 2** Using Tweezers or needle-nose pliers, carefully remove bulb.
- Take unit to servicenter if you need assistance.

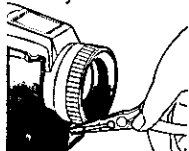

Before you begin

- Set POWER to OFF.

- 3** Replace bulb using a clean cloth or tissue. (Do not touch with fingers.)

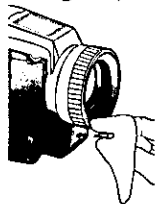

- 4** Replace lens cover.

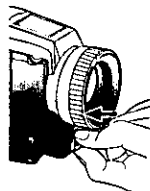

Note

- Handle bulb gently. Excessive force may cause bulb to crack.

DANGER:

Use only replacement bulb (PART NO. LSL0028) supplied by Panasonic to reduce risk of fire. Handle new bulb with cloth or tissue as skin oils decrease bulb life. Remove lens cover and allow bulb to cool before replacing to avoid possible burn hazard.

Notice

This product has a fluorescent lamp that contains a small amount of mercury. It also contains lead in some components. Disposal of these materials may be regulated in your community due to environmental considerations. For disposal or recycling information please contact your local authorities, or the Electronics Industries Alliance: <<http://www.eiae.org>>

Concerning the Memory Card (Optional) (MultiMediaCard and SD Memory Card)

- Model PV-DV102 can be used with either a MultiMediaCard or a SD Memory Card.
- Both of these exterior Memory Cards (MultiMediaCard and SD Memory Card) are lightweight and removable.
- Both Memory Cards (MultiMediaCard and SD Memory Card) are offered in a variety of memory sizes, so you can purchase a higher capacity Memory Card if desired.

For Your Information

Notes On Operations

Approximate Brightness Values

Your Palmcorder has been designed for normal scene illumination of 150 footcandles (1500 lx). However, the Palmcorder may be used at F1:1.8, if illumination is more than 0.5 footcandles (5 lx).

The table below shows the color temperature for reference.

PALMCORDER SETTINGS	NATURAL LIGHT CONDITIONS	KELVIN COLOR TEMPERATURE	ARTIFICIAL LIGHT SOURCE	COLOR TINT MIXTURE	
	<ul style="list-style-type: none"> Fair weather, blue sky 	10,000	<ul style="list-style-type: none"> Color television 	Bluish	
	<ul style="list-style-type: none"> Slightly cloudy sky 	8,000			
	<ul style="list-style-type: none"> Cloudy or rainy sky 	7,000			
	<ul style="list-style-type: none"> Sunlight in clear weather at midday 	6,500	<ul style="list-style-type: none"> Fluorescent lamp (Daylight) Camera flash bulb 		
	<ul style="list-style-type: none"> Average sunlight in clear weather 	6,000			
	<ul style="list-style-type: none"> Sunlight 2 hours after sunrise and before sunset 	5,500			
	<ul style="list-style-type: none"> Sunlight 40 min. after sunrise and before sunset 	5,000	<ul style="list-style-type: none"> Blue lamp for photography 		
	<ul style="list-style-type: none"> Sunlight 30 min. after sunrise and before sunset 	4,500		<ul style="list-style-type: none"> Fluorescent lamp (White) Normal flash bulb Fluorescent lamp (Off-white) 	Whitish
	<ul style="list-style-type: none"> Sunlight 20 min. after sunrise and before sunset 	4,000		<ul style="list-style-type: none"> Tungsten lamp for photography 	
	<ul style="list-style-type: none"> Sunlight 10 min. after sunrise and before sunset 	3,500		<ul style="list-style-type: none"> Halogen lamp Iodine lamp 	
<ul style="list-style-type: none"> Sunlight 5 min. after sunrise and before sunset 	3,200		<ul style="list-style-type: none"> Tungsten lamp Acetylene lamp Kerosene lamp 	Yellowish	
<ul style="list-style-type: none"> Sunlight 3 min. after sunrise and before sunset 	2,800		<ul style="list-style-type: none"> Candlelight 	Reddish	
	2,000				

Specifications

Power Source:	Palmcorder: 7.2 V DC (Battery) 7.8 V DC (AC Adaptor) AC Adaptor: 110/120/220/240 V AC, 50/60 Hz Battery: Lithium-Ion Type DC 7.2 V
Power Consumption:	Palmcorder : 7.2 V/7.8 V DC 6.5 W (Max. 9.5 W) AC Adaptor : 18 W 1 W (when not in use.)
Digital Interface	USB/i.LINK (IEEE1394)
Video Signal:	EIA Standard (525 lines, 60 fields) NTSC color signal
Video Recording System:	2 rotary heads. helical scanning system
Audio:	12 bit (32 kHz) 4 tracks 16 bit (48 kHz) 2 tracks
Pick-Up System and Device:	One integral color filter Charge Coupled Device (CCD)
Lens:	10:1 zoom lens, F1:1.8 with auto iris control Focal length: 3.6 mm - 36 mm Power zoom function Lens filter diameter: 43 mm
Viewfinder:	5.3 mm (0.21 inch) Liquid Crystal Electronic Viewfinder
LCD Monitor:	63.5 mm (2.5 inch) Liquid Crystal Display
Minimum Illumination Required:	5 lx (F1:1.8) 0.5 footcandles
Memory (Still image)	MultiMediaCard/SD Memory Card 640 x 480 pixels (NORMAL mode) 1,280 x 960 pixels (FINE mode)
Image Storage (Optional 8 MB Memory Card)	Approx. 70 images (NORMAL mode) Approx. 30 images (FINE mode)
Image Format	JPEG (Design Rule for Camera File System)
Operating Temperature:	32 °F~104 °F (0 °C~40 °C)
Operating Humidity:	10 %~75 %
Weight:	Palmcorder: 0.58 kg 1.28 lbs. AC Adaptor: 0.16 kg 0.35 lbs.
Dimensions:	Palmcorder: 88.5 (W) x 74 (H) x 182 (D) mm 3-1/2 (W) x 2-7/8 (H) x 7-1/8 (D) inch AC Adaptor: 70 (W) x 45 (H) x 115 (D) mm 2-3/4 (W) x 1-3/4 (H) x 4-1/2 (D) inch

Weight and dimensions shown are approximate.
Designs and specifications are subject to change without notice.

Before Requesting Service

Cleaning Care for Video Heads

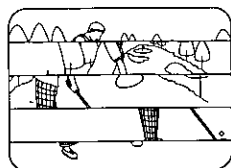

Clogged Video Head

(a) Video Head Cleaning: Normally, your Palmcorder will not require head cleaning. However, it is possible that the heads may become clogged due to dust in the air, playing damaged tapes, long term use, etc. If "NEED HEAD CLEANING" appears for 5 seconds in the EVF or LCD monitor, the heads may require cleaning.

(b) Cleaning the Heads: It is recommended that head cleaning be performed by a qualified service technician. Please contact your nearest Panasonic Servicenter. An alternate solution is to obtain a head cleaning cassette. Please use Panasonic cleaning cassette (AY-DVMCLA). Be sure to follow the cleaning instructions carefully. Excessive use of the head cleaning cassette could shorten video head life.

Use this cassette only when a head clogging symptoms occur.

Refer servicing to qualified service personnel.

Tape Operations Caution

- When you go from function to function (PLAY, FF, REW etc.), please note that the unit will not accept a new function operation until the previous operation is complete.
- The POWER Button and all function buttons, (PLAY, FF, REW, etc.) are only operational after the tape has been completely loaded.

Lens Hood Area Operation Caution

When the following accessories are attached and the zoom is set to maximum wide angle, the four corners of the screen may appear darker:

- Wide or Telephoto conversion lens (optional).
- A filter (optional), etc. and then the lens hood.
- Two filters (optional).

Self Diagnostic System

If any of the following numbers appear on-screen, the camcorder may need service. Do not remove the battery (if attached) and write down the displayed number on page 97. Then, take the camcorder to a servicenter for repair.

Error No.	Description
U11	Card Error
U12	Card Error
U13	Card Error
U14	Card/Camcorder Dialogue Error
U15	Card Access Error
U16	Card Access Error
U30	Error other than above

Before Requesting Service







If you have a problem with your Palmcorder, it may be something you can correct yourself.

Check the list below for symptoms and corrections.

Symptom	Correction
No picture in the EVF or LCD Monitor...	<ul style="list-style-type: none">• Make sure the Power Source is connected. (pp. 13, 14)• Make sure the POWER switch is set to VCR or CAMERA. (pp. 17, 31)• Check the Dew Indicator. (p. 96)• Make sure the Battery is fully charged. (p. 13)• Make sure all necessary cables are connected correctly and firmly. (p. 14)• Make sure the Lens Cap is removed. (p. 17)
Video cassette cannot be inserted...	<ul style="list-style-type: none">• Make sure the Power Source is connected. (pp. 13, 14)• Insert the cassette record tab up, window side facing out. (p. 10)
Video cassette cannot be removed...	<ul style="list-style-type: none">• Make sure the Power source is connected. (pp. 13, 14)
No operation starts when operation buttons are pressed..	<ul style="list-style-type: none">• Check the Dew Indicator. (p. 96)
Recording cannot be done...	<ul style="list-style-type: none">• Make sure the record tab is closed. (p. 6)• Check the Battery Indication. (p. 108)
Auto Focus does not operate...	<ul style="list-style-type: none">• Make sure FOCUS is set to AUTO. (p. 28)• Make sure the unit is ON and set to CAMERA mode. (p. 17)
Sound from microphone cannot be monitored...	<ul style="list-style-type: none">• Make sure the unit is set to REC or REC/ PAUSE mode.
Sound cannot be heard...	<ul style="list-style-type: none">• Make sure the Audio on the VCR MENU is set to ST1. (pp. 43, 106)

On-Screen Displays (OSD)

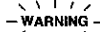
The following warning displays appear in the EVF and the LCD monitor.

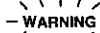
Indications	Condition
 TAPE NOT INSERTED	If the Palmcorder is in CAMERA mode without a cassette inserted, "TAPE NOT INSERTED" will flash and "TAPE NOT INSERTED" will appear for 5 seconds. Recording will not start.
 CHECK REC TAB	If the Palmcorder is in CAMERA mode or Audio dub mode with the cassette sliding record tab opened, "CHECK REC TAB" will flash and "CHECK REC TAB" will appear for 5 seconds. Recording will not start.
 CANNOT REC	When Audio dub is performed and the recording in other than NTSC format, "CANNOT REC" will flash and "CANNOT REC" will appear for 5 seconds.
 TAPE END	When the tape is about to end in REC mode, "TAPE END" will flash and "TAPE END" will appear for 5 seconds.
INCOMPATIBLE TAPE	When an incompatible tape is detected, "INCOMPATIBLE TAPE" will appear for 5 seconds.
NEED HEAD CLEANING	If the video heads require cleaning, "NEED HEAD CLEANING" will appear for 5 seconds.
REMOTE	When the Palmcorder and remote are not set to the same mode (VCR1 or VCR2), "CHECK REMOTE MODE (REMOTE)" appears for 5 seconds. It also appears when the Palmcorder is first turned on.
CANNOT REC LP-MODE	When an AUDIO DUB is attempted on a pre-recorded LP tape, "CANNOT REC LP-MODE" will appear for 5 seconds.
 DEW DETECTED	If excessive moisture condenses in the unit, "WARNING" will flash, "DEW DETECTED" will appear, and the Palmcorder will automatically turn OFF in 15 seconds. In this case, wait until the indicator no longer flashes when your Palmcorder is turned ON again.
  LOW BATTERY	When a battery recharge is necessary, "WARNING" will flash, "LOW BATTERY" will appear, and the Palmcorder will automatically turn OFF in 15 seconds. (p. 108)
CLOCK BATTERY	When the built-in lithium clock battery is discharged, "CLOCK BATTERY" will appear. To re-charge the lithium clock battery, connect the AC Adaptor to the Palmcorder. Recharging takes approx. 4 hours. Reset the clock after charging.

On-Screen Displays (OSD)

Indications	Condition
INCOMPATIBLE DATA	If you play a tape recorded in a format other than NTSC or you try to copy copy-protected data, "INCOMPATIBLE DATA" will appear.
NO SPACE LEFT	When a still image is transferred from a tape to an already full Memory Card, or when setting is DPOF, "NO SPACE LEFT" appears.
DISCONNECT DV CABLE	If the Palmcorder is in M-CARD mode or Photo Title (CAMERA mode) and the DV Interface Cable (i.LINK) is connected, "DISCONNECT DV CABLE" appears. In this case, remove the DV Interface Cable (i.LINK) from the Palmcorder.
WRITE PROTECTED	In M-CARD mode, this display appears if the SD Memory Card Lock Switch is in the Lock position.

Request for Service Notice

Please photocopy this form when making a request for service notice.

Request for Service Notice:

In the unlikely event this product needs service.

- Please include your **proof of purchase**. (Failure to do so will delay your repair.)
- To further speed your repair, please provide an explanation of what is wrong with the unit and any symptom it is exhibiting.

Mail this completed form and your Proof of Purchase along with your unit to:

Panasonic Services Company
1705 N. Randall Road
Elgin, IL. 60123-7847
Attn: Camcorder Repair

Please write the displayed Self Diagnostic number here. (p. 94)

For Your Information

Limited Warranty

Panasonic Consumer Electronics Company,
Division of Matsushita Electric Corporation
of America, One Panasonic Way
Secaucus, New Jersey 07094

Panasonic Sales Company,
Division of Matsushita Electric of Puerto Rico, Inc.
AVE. 65 de Infanteria, Km. 9.5 San Gabriel
Industrial Park, Carolina, Puerto Rico 00985

PANASONIC/QUASAR Video Products Limited Warranty

Panasonic Consumer Electronics Company or Panasonic Sales Company (collectively referred to as "the Warrantor") will repair or replace this product with new or refurbished parts or equivalent product, free of charge, in the USA or Puerto Rico, in the event of a defect in materials or workmanship as follows (all time periods commence from the date of the original purchase):

PRODUCT	PARTS	LABOR	SERVICE	CONTACT NUMBER
CAMCORDER	ONE (1) YEAR, EXCEPT CCD IMAGE SENSOR CCD IMAGE SENSOR - SIX (6) MONTHS	NINETY (90) DAYS	Carry-In or Mail-In	1-800-211-PANA(7262)
		NINETY (90) DAYS		
DVD/VCR DECK	ONE (1) YEAR	NINETY (90) DAYS	Carry-In or Mail-In	1-800-211-PANA(7262)
DIGITAL STILL CAMERA	ONE (1) YEAR, EXCEPT CCD IMAGE SENSOR CCD IMAGE SENSOR - SIX (6) MONTHS	NINETY (90) DAYS	Carry-In or Mail-In	1-800-272-7033
		NINETY (90) DAYS		
AV MIXER	ONE (1) YEAR	NINETY (90) DAYS	Carry-In or Mail-In	1-800-211-PANA(7262)
TV/VCR, TV/DVD TV/DVD/VCR COMBINATION	ONE (1) YEAR, EXCEPT CRT CRT - TWO (2) YEARS	NINETY (90) DAYS	Carry-In: 21" CRT and Smaller	1-800-211-PANA(7262)
		CRT - NINETY (90) DAYS	In-Home or Carry-In: 22" CRT and Larger	
TV/HDR COMBINATION	ONE (1) YEAR, EXCEPT CRT CRT - TWO (2) YEARS	NINETY (90) DAYS CRT - NINETY (90) DAYS	In-Home or Carry-In	1-888-843-9788

Batteries (if included) - New rechargeable batteries in exchange for defective rechargeable batteries for ten (10) days. Non-rechargeable batteries are not warranted.

Tap (if included) - New video cassette tape in exchange for a defective video cassette tape for five (5) days.

Memory cards (if included) - Exchange defective item for new one for ninety (90) days.

In-home, carry-in or mail-in service, as applicable, in the USA can be obtained during the warranty period by contacting a Panasonic Services Company (PASC) Factory Servicenter listed in the Servicenter Directory. Or call toll free contact number listed above, to locate an authorized PASC Servicenter. Carry-in or mail-in service in Puerto Rico can be obtained during the warranty period by calling the Panasonic Sales Company telephone number listed in the Servicenter Directory.

This warranty is extended only to the original purchaser. A purchase receipt or other proof of the date of the original purchase is required before warranty service is rendered.

This warranty only covers failures due to defects in materials and workmanship, which occur during normal use and does not cover normal maintenance, including, but not limited to, video and audio head cleaning. The warranty does not cover damage which occurs in shipment, or failures which are caused by products not supplied by the warrantor, or failures which result from accident, misuse, abuse, neglect, mishandling, misapplication, alteration, modification, faulty installation, set-up adjustments, improper antenna, inadequate signal pickup, maladjustment of consumer controls, improper operation, power line surge, improper voltage supply, lightning damage, commercial use such as hotel, office, restaurant, or other business or rental use of the product, or service by anyone other than a PASC Factory Servicenter or a PASC authorized Servicenter, or damage that is attributable to acts of God.

LIMITS AND EXCLUSIONS

There are no express warranties except as listed above.

THE WARRANTOR SHALL NOT BE LIABLE FOR INCIDENTAL OR CONSEQUENTIAL DAMAGES (INCLUDING, WITHOUT LIMITATION, DAMAGE TO RECORDING MEDIA) RESULTING FROM THE USE OF THIS PRODUCTS, OR ARISING OUT OF ANY BREACH OF THE WARRANTY. ALL EXPRESS AND IMPLIED WARRANTIES, INCLUDING THE WARRANTIES OF MERCHANTABILITY AND FITNESS FOR PARTICULAR PURPOSE, ARE LIMITED TO THE APPLICABLE WARRANTY PERIOD SET FORTH ABOVE.

Some states do not allow the exclusion or limitation of incidental or consequential damages, or limitations on how long an implied warranty lasts, so the above exclusions or limitations may not apply to you.

This warranty gives you specific legal rights and you may also have other rights, which vary, from state to state. If a problem with this product develops during or after the warranty period, you may contact your dealer or Servicenter. If the problem is not handled to your satisfaction, then write to the Consumer Affairs Department at the Panasonic Consumer Electronics Company address above.

SERVICE CALLS WHICH DO NOT INVOLVE DEFECTIVE MATERIALS OR WORKMANSHIP AS DETERMINED BY THE WARRANTOR, IN ITS SOLE DISCRETION, ARE NOT COVERED.

COSTS OF SUCH SERVICE CALLS ARE THE RESPONSIBILITY OF THE PURCHASER.

warvid 02/ 12/ 2001

Servicenter List

For Product Information, Operating Assistance, Literature Request, Dealer Locations, and all Customer Service inquiries please contact:
1-800-211-PANA (7262), Monday-Friday 9 am-9 pm; Saturday-Sunday 9 am-7 pm, EST.
or send e-mail to : consumerproducts@panasonic.com

Web Site: <http://www.panasonic.com>
You can purchase parts, accessories or locate your nearest servicenter by visiting our Web Site.

Accessory Purchases:

1-800-332-5368 (Customer Orders Only)
Panasonic Services Company 20421 84th Avenue South, Kent, WA 98032
(6 am to 5 pm Monday - Friday; 6 am to 10:30 am Saturday; PST)
(Visa, MasterCard, Discover Card, American Express, Check)

Factory Servicenters Locations

CALIFORNIA

6550 Katella Avenue
Cypress, CA 90630

800 Dubuque Avenue
S. San Francisco,
CA 94080

3878 Ruffin Road
Suite A
San Diego, CA 92123

FLORIDA

3700 North 29th Avenue
Suite 102
Hollywood, FL 33020

GEORGIA

8655 Roswell Road
Suite 100
Atlanta, GA 30350

ILLINOIS

1709 North Randall Road
Elgin, IL 60123

MASSACHUSETTS

60 Glacier Drive
Suite G
Westwood, MA 02090

MINNESOTA

7850-12th Avenue South
Airport Business Center
Bloomington, MN 55425

OHIO

2236 Waycross Road
Civic Center Plaza
Forest Park, OH 45240

PENNSYLVANIA

2221 Cabot Blvd. West
Suite B
Langhorne, PA 19047

TEXAS

13615 Welch Road
Suite 101
Farmers Branch,
TX 75244

WASHINGTON

20425-84th Avenue
South
Kent, WA 98032

HAWAII

99-859 Iwaiwa Street
Aiea, Hawaii 96701
Phone (808) 488-1996
Fax (808) 486-4369

Service in Puerto Rico

Matsushita Electric of Puerto Rico, Inc. Panasonic Sales Company/ Factory Servicenter:
Ave. 65 de Infantería. Km. 9.5, San Gabriel Industrial Park, Carolina, Puerto Rico 00985
Phone (787) 750-4300 Fax (787) 768-2910

As of Sep. 2001

Precauciones para su seguridad

ADVERTENCIA: PARA EVITAR INCENDIOS Y DESCARGAS ELÉCTRICAS, NO EXPONGA ESTE EQUIPO A LA LLUVIA NI A LA HUMEDAD.

Su ^{Mini}IN Palmcorder está diseñada para grabar y reproducir en el modo de Reproducción Estándar (SP) y modo Largo (LP).

Se recomienda el uso sólo de cintas de cassette que hayan sido probadas e inspeccionadas para su uso en aparatos VCR con la marca ^{Mini}IN.

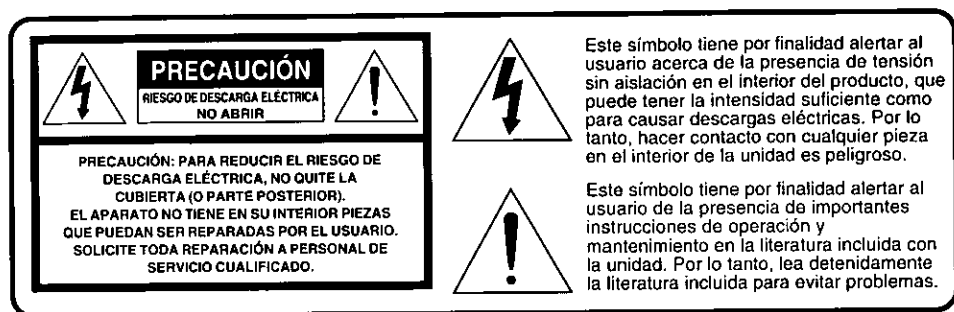

La etiqueta de régimen está pegada en la base de la cubierta del cargador.

Este dispositivo cumple con la parte 15 de las Reglas del FCC. El funcionamiento está sujeto a las dos siguientes condiciones: (1) Este dispositivo puede no causar interferencias perjudiciales, y (2) este dispositivo debe aceptar cualquier interferencia recibida, incluyendo interferencias que pueden causar un funcionamiento no deseado.

Nota: Este equipo ha sido puesto a prueba y se encontró que cumple con la Parte 15 de las reglas del FCC. Estos límites están diseñados para proveer una protección razonable contra interferencias cuando se opera en un ambiente residencial.

Si este equipo causa interferencias en la recepción de radio o televisión, lo cual se puede comprobar al apagar y encender el equipo, utilice el equipo en otra ubicación y/o utilice un tomacorriente diferente al que está utilizando el receptor. Si es necesario, consulte con el distribuidor o un técnico experto de radio/TV para solicitar ayuda. Puede encontrar útil el folleto 'Información sobre las interferencias' disponible en las oficinas regionales del FCC local.

Advertencia del FCC:

Para asegurar la conformidad continua del FCC, utilice solamente el cable de interfaz blindado cuando conecte una cámara de video digital a una computadora de acuerdo con las instrucciones incluidas aquí. También, cualquier cambio sin autorización o modificaciones a este equipo anularían la autoridad del usuario para operarlo.

Spanish Quick Use Guide/Guía Para Uso Rápido

Inserte de la batería

Antes de comenzar

- Cargue la batería. (Página 13.)

Film de protección

Nota

- Retire la película protectora antes de utilizarlo.

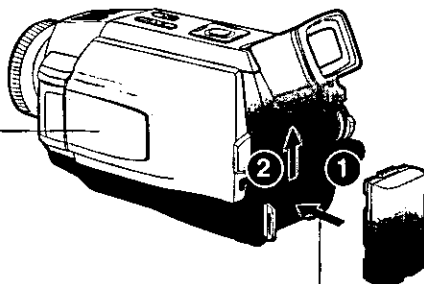

- 1 Coloque la batería y deslícela hacia arriba hasta que se quede bloqueada con un clic.

Insert Cassette

Esta videocámara contiene un sistema de ejecución fácil del cassette. Por eso, es fácil de introducir o sacar el cassette aunque esté montado sobre un trípode. (Página 7.)

- 1 Presione LCD-OPEN y abra completamente el monitor LCD.

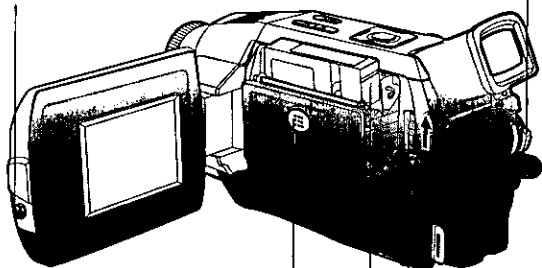

- 2 Ajuste el interruptor de alimentación (POWER) a la posición VCR o CAMERA.

- 3 Deslice el interruptor de expulsión de cinta (TAPE EJECT) para abrir la tapa del compartimento del cassette.

- 5 Presione la marca PUSH TO CLOSE (EMPUJAR PARA CERRAR) para cerrar la tapa del compartimento del cassette.

- 4 Introduzca un cassette con la parte de la ventana hacia arriba.
 - Asegúrese de que la lengüeta de grabación esté cerrada. (Página 6.)

Grabación con la cámara

Cuando el monitor LCD se encuentra totalmente abierto, el visor se DESACTIVA automáticamente.

- 1** Ajuste el interruptor de alimentación (POWER) a la posición CAMERA.

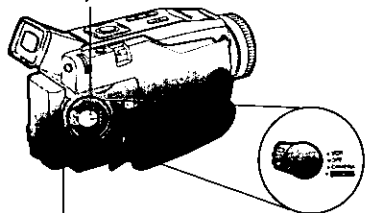

- 2** Ajuste el control de ajuste de visión según lo desee.

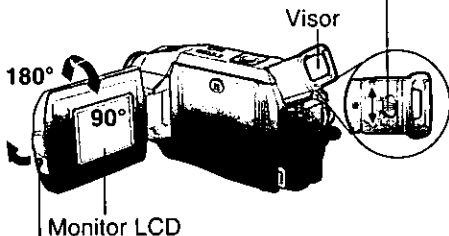

- 4** Presione el botón de grabación/pausa (REC/PAUSE) para iniciar la grabación. Vuelva a pulsar el botón de grabación/pausa (REC/PAUSE) para hacer una pausa en la grabación.

- 3** Presione el botón de apertura del LCD (LCD-OPEN) para desbloquear el monitor LCD. Balancee abriéndolo completamente y ajuste el ángulo.

Para ver la reproducción en el LCD (pantalla de visualización de cristal líquido)

Cuando el monitor LCD se encuentra totalmente abierto, el visor se DESACTIVA automáticamente.

Antes de comenzar

- Cargue la batería. (Página 13.)

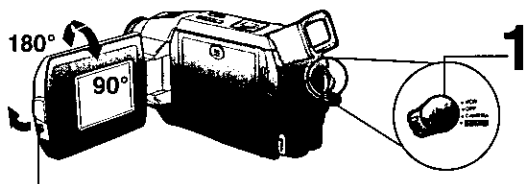

- 2** Presione el botón de apertura del LCD (LCD-OPEN) para desbloquear el monitor LCD. Balancee abriéndolo completamente y ajuste el ángulo.

- 3** Presione el botón de rebobinado (REW) para rebobinar la cinta.

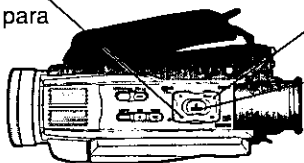

- 1** Ajuste el interruptor de alimentación (POWER) a la posición VCR.

- 4** Presione el botón de reproducción (PLAY) para reproducir la cinta.

- 5** Presione el botón de parada (STOP) para detener la reproducción.

Spanish Quick Use Guide/Guía Para Uso Rápido

Introducir la Tarjeta de memoria (Opcional)*

Antes de comenzar

- Cargue la batería. (Página 13.)

- *Tarjeta de Memoria: Tarjeta MultiMedia o Tarjeta de Memoria SD (Página 91.)
- Asegúrese de introducir la Tarjeta de memoria antes de utilizar la tarjeta PhotoShot. (Página 47.)

A continuación se indican una lista de Tarjetas de Memoria soportadas por esta unidad.

Memory Card	Capacity
Tarjeta MultiMedia (Marca de fábrica SanDisk)	8 MB, 16 MB
Tarjeta de Memoria SD (opcional) (Página 89.)	16 MB, 32 MB, 64 MB

Botón para la protección de copia de la tarjeta de memoria SD



La tarjeta de memoria SD tiene un botón para la protección de copia. Deslice el botón hacia la dirección de LOCK para prevenir una copia o cambio de la estructura de la tarjeta.

↑ Botón para la protección de copia

- 1** Ajuste el interruptor de alimentación (POWER) a la posición OFF.
- 2** Deslice el botón CARD EJECT para abrir la tapa del compartimiento de la tarjeta de memoria.
- 3** Introduzca la tarjeta de memoria hasta que se coloque en su sitio con un clic.
- 4** Cierre la puerta de M-CARD.

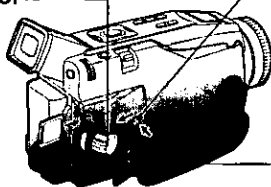

Para quitar la tarjeta de memoria...

Presione aquí para quitar la tarjeta.



Acerca del seguro M-CARD

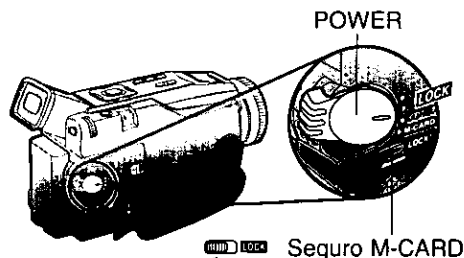

Seguro M-CARD

Al insertar la tarjeta de memoria

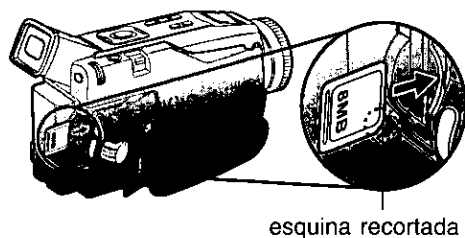

esquina recortada

Nota

- Deslizando el seguro M-CARD a la posición LOCK, evitara que POWER gire por error a la posición M-CARD al cambiar POWER a CAMERA.

Nota

- Al insertar la tarjeta de memoria, insértela con la esquina recortada hacia abajo tal como se indica en la figura anterior.

Camera Mode Menu Screen

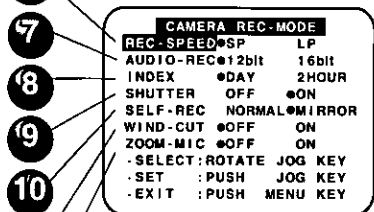
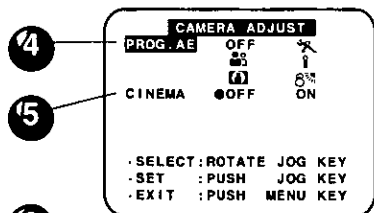
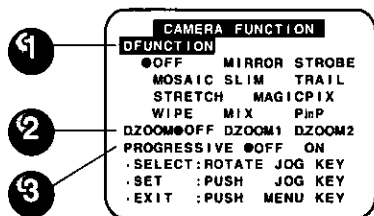

- 1 D.FUNCTION** (pp. 40, 42)
To select one of the 10 digital functions.
Setting to OFF cancels the previously selected digital function.
- 2 D.ZOOM** (p. 39)
To select D.ZOOM1 (from 10X to 25X) or D.ZOOM2 (from 10X to 700X).
Setting to OFF cancels the previously selected digital zoom.
- 3 PROGRESSIVE** (p. 19)
When set to ON, still pictures taken with PhotoShot are recorded with a higher resolution than with normal PhotoShot.

- 4 PROG. AE** (p. 23)
To select one of the 5 Program AE modes. Setting to OFF cancels the previously selected Program AE mode.
- 5 CINEMA** (p. 22)
When set to ON, you can record a picture compatible with a wide-screen TV equipped with an S2 picture terminal.
- 6 REC-SPEED** (pp. 6, 17)
SP: Normal recording speed mode.
LP: Recording time is 1.5 times as long as in the SP mode. For example, 120 minutes of recording is possible on a 80 minute tape.
- 7 AUDIO-REC** (p. 43)
12 bit: The sound is recorded in the 12 bit/32 kHz mode.
16 bit: The sound is recorded in the 16 bit/48 kHz high-quality mode.
- 8 INDEX**
DAY: An index signal is recorded when recording is restarted after the date has changed since the last recording.
2 HOUR: An index signal is recorded when recording is restarted after a lapse of more than 2 hours.
- 9 SHUTTER** (pp. 19, 47)
When set to ON, still pictures taken in the PhotoShot mode are recorded with a visual shutter effect and click sound.
- 10 SELF-REC** (p. 21)
NORMAL: During self-recording, the picture on the LCD Monitor is the same as it will be recorded.
MIRROR: During self-recording, the picture on the LCD Monitor is horizontally reversed.
- 11 WIND-CUT** (p. 30)
To reduce sound distortion caused by wind hitting the microphone.
- 12 ZOOM-MIC** (p. 20)
When set to ON, the microphone's directional angle and sensitivity vary according to the zoom operation.

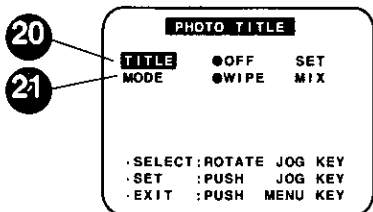
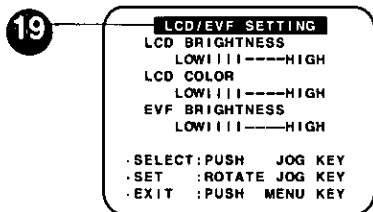
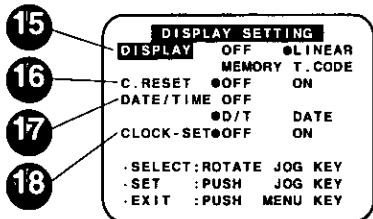
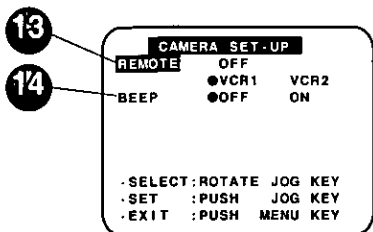

- 13** REMOTE (p. 9)
- VCR1:** To receive signals from the Remote Control, set to VCR1.
- VCR2:** To receive signals from the Remote Control, set to VCR2.
- OFF:** To prevent reception of signals from the Remote Control.

- 14** BEEP
- Set to ON to hear beep when starting and stopping camera recording or when unusual conditions occur. To cancel the beep, set to OFF.
- Palmcorder will beep:
Once when you start recording
Twice when you stop recording
Repeatedly when warning of unusual conditions.
(pp. 96, 97)

- 15** DISPLAY (p. 109)
- To select the desired type of display and counter indication displayed on the LCD Monitor or in the viewfinder.

- 16** C.RESET (p. 109)
- Setting to ON resets the counter to zero.

- 17** DATE/TIME (p. 108)
- The date and time can be set and displayed on the screen.

- 18** CLOCK-SET (p. 15)
- When set to ON, the date and time can be set on the screen.

- 19** LCD/EVF SETTING (p. 18)
- Setting to ON displays the menu for adjusting the LCD brightness, color level, and the EVF brightness.

- 20** TITLE (p. 26)
- Photo Title is recorded.

- 21** MODE (p. 26)
- To select one of the 2 Photo Title modes.

MENU OSD

VCR Mode Menu Screen

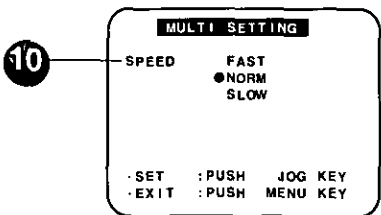
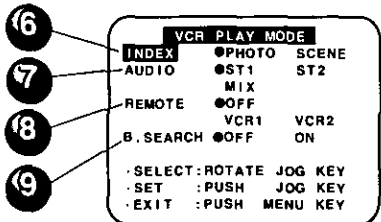
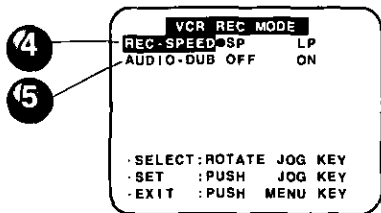
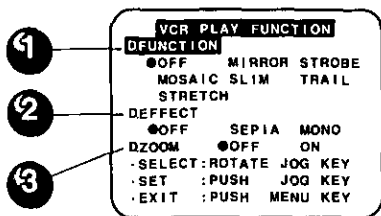

- 1** **D.FUNCTION** (p. 42)
To select one of the 6 digital functions.
Setting to OFF cancels the previously selected digital function.
- 2** **D.EFFECT** (p. 42)
To select one of the 2 digital picture effects for playback. Setting to OFF cancels the previously selected digital effect.
- 3** **D.ZOOM** (p. 40)
Set to ON to double the size of a playback image. Setting to OFF cancels the previously selected digital zoom.

- 4** **REC-SPEED** (p. 6)
SP: Normal recording speed mode.
LP: Recording time is 1.5 times as long as in the SP mode. For example, 120 minutes of recording is possible on an 80 minute tape.
- 5** **AUDIO-DUB** (p. 43)
Set to AUDIO-DUB "ON" in the Menu OSD to use the Audio Dub feature.
- 6** **INDEX** (pp. 35, 36)
To select the desired Index Search function.
PHOTO: To search for Photo shot pictures.
SCENE: To search for scenes marked with Index signal.
- 7** **AUDIO** (p. 44)
To select the desired audio playback mode after performing audio dubbing in the 12 bit mode (SP mode only).
ST1: The original sound alone is played back.
ST2: The dubbed sound alone is played back.
MIX: The original sound and the dubbed sound are played back together.
- 8** **REMOTE** (p. 9)
VCR1: To receive signals from the Remote Control, set to VCR1.
VCR2: To receive signals from the Remote Control, set to VCR2.
OFF: To prevent reception of signals from the Remote Control.

- 9** **B.SEARCH (Blank Search)** (p. 32)
Select ON to go directly to a blank portion of the tape.
- 10** **SPEED** (p. 37)
In Strobe Multi mode, used to select the interval at which a succession of still screens are captured from the playback picture.
FAST: Every 0.3 seconds
NORM: Every 0.6 seconds
SLOW: Every 1.0 seconds

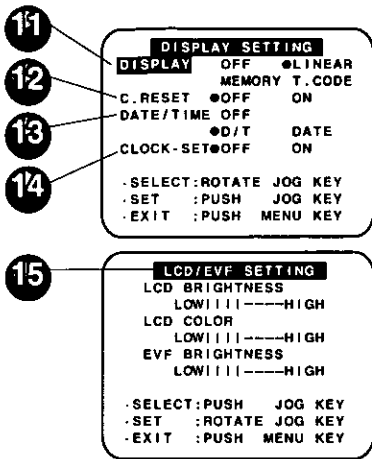

- 11** **DISPLAY** (p. 109)
To select the desired type of display and counter indication displayed on the LCD Monitor or in the viewfinder.
- 12** **C.RESET** (p. 109)
Setting to ON resets the counter to zero.
- 13** **DATE/TIME** (p. 108)
The date and time can be set and displayed on the screen.
- 14** **CLOCK-SET** (p. 15)
When set to ON, the date and time can be set on the screen.
- 15** **LCD/EVF SETTING** (p. 18)
Setting to ON displays the menu for adjusting the LCD brightness, color level, and the EVF brightness.

M-CARD Mode Menu Screen

[Photo Rec Mode Menu Screen]

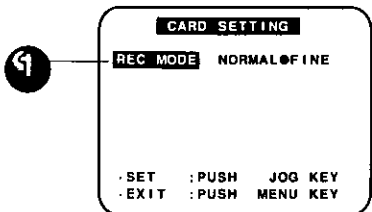

[Photo Play Mode Menu Screen]

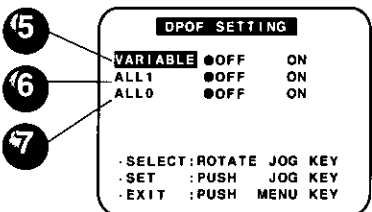
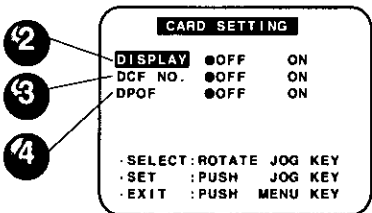

- 1** **REC MODE** (p. 47)
To select Photo Rec Mode.
- 2** **DISPLAY** (p. 111)
Select to OFF to cancel all Displays on the screen.
- 3** **DCF NO.** (pp. 49, 111)
Select to OFF to cancel DCF (Design rule for Camera File system) No. on the screen.
- 4** **DPOF** (pp. 53, 111)
When set to ON, information of the image to be printed and the number of prints desired (DPOF data) is written to the Memory Card.
- 5** **VARIABLE** (p. 53)
When set to ON, you can select images recorded on the Memory Card and set the number of prints desired.
- 6** **ALL1** (p. 53)
When set to ON, the number of prints recorded on the Memory Card is collectively set to 1.
- 7** **ALL0** (p. 53)
When set to ON, the currently set number of prints is set to 0.

Electronic Viewfinder/LCD Monitor Indications

Here are some of the basic indications which will appear on the Palmcorder EVF and LCD Monitor. Only Date and Time indications will be recorded onto the tape.

CAMERA/VCR Mode

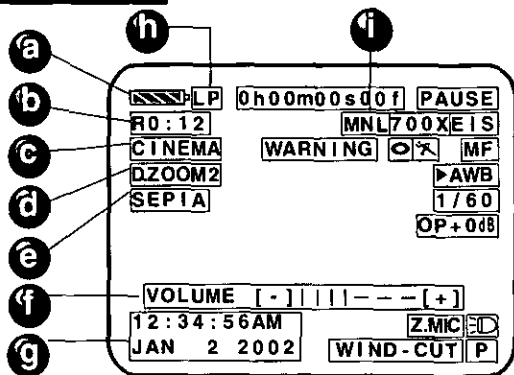

a Battery Remaining

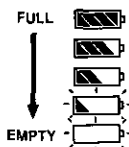

b Tape Remaining

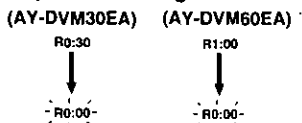

- It will take several seconds for the tape remaining indicator to operate after the tape starts moving.

c CINEMA Indication

(Menu OSD: p. 104)

d Digital Zoom and other Digital Functions

(Menu OSD: p. 104)

This display appears when the digital zoom function has been activated.

e Playback Effect

(Menu OSD: p. 106)

This display appears when SEPIA or MONO is selected in VCR menu.

f Volume Display

(p. 32)

The volume bar appears when the volume of the built-in speaker is being adjusted.

g Date and Time Indication

(Menu OSD: pp. 105, 107)

As shown below, the date and time indication changes each time DATE/TIME is selected from the Palmcorder's MENU (Menu OSD: pp. 105, 107) or the DATE/TIME Button is pressed on the remote.

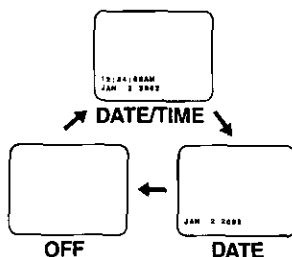

h Tape Speed Indication

(Menu OSD: p. 104)

Indicates the tape speed (SP or LP).

i MNL Indication

(pp. 27-30)

This display appears when AUTO/MANUAL is pressed to MANUAL.

Electronic Viewfinder/LCD Monitor Indications

CAMERA/VCR Mode

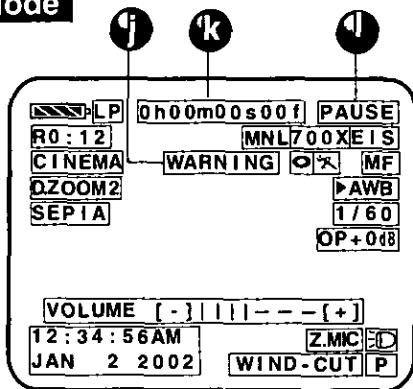

j **WARNING** Indication (pp. 96, 97)
The warning displays appear in the EVF and the LCD monitor.

k **Display ON/OFF and Counter/Time Code**
The indication switches as shown below when the desired "DISPLAY" mode is selected from the menu. (Menu OSD: pp. 105, 107)
• When OFF is selected, all displays are turned off.

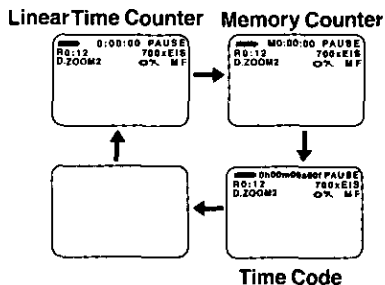

Memory Counter M 0:00:00

The Palmcorder will stop whenever it reaches the point where the counter was previously set to M 0:00:00 during audio dub, fast forward, or rewind.

Time Code 0h00m00s00f

The Palmcorder calculates and displays exactly where you are on any tape in terms of hours, minutes, seconds, and frames (30 frames = 1 second).

• This display cannot be reset.

IMPORTANT NOTE:

- Display must be set to ON for MF, AE, W.BALANCE or BACK LIGHT indications to be displayed on the EVF or LCD Panel when selected.
- C.RESET does not work when DISPLAY is set to OFF and T.CODE.

l **Tape Mode Indications**

REC	Recording.
PHOTO	PhotoShot recording.
PAUSE	Paused during recording.
▷	Playback.
	Still.
▷	Slow (forward).
◁	Slow (reverse).
▷	Frame Advance (forward).
◁	Frame Advance (reverse).
R▷	Repeat Playback.
CHK	Recording Check.
FF	Fast forward.
REW	Rewind.
▷▷	FF Search.
◁◁	REW Search.
BLANK	Blank Search.
SEARCH	Index Search.

CAMERA/VCR Mode

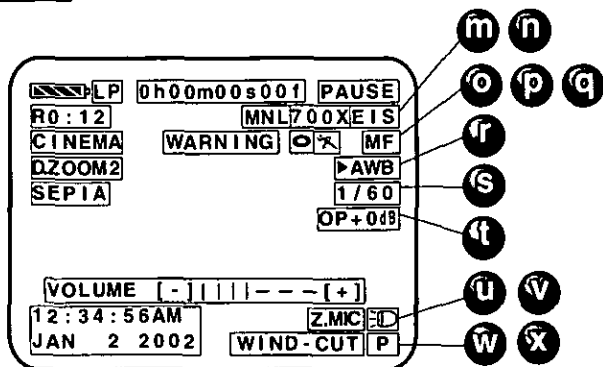

- m** **Zoom Magnification Level** (p. 39)
- n** **Digital EIS Indications** (p. 41)
This display appears when EIS is pressed.
- o** **Backlight Indication** (p. 22)
This display appears when BACK LIGHT is pressed.
- p** **PROGRAM-AE Indication** (p. 23)
- q** **Manual Focus Indication** (p. 28)
- r** **White Balance Indication** (p. 27)
- s** **Shutter Mode Indication** (p. 29)
- t** **Iris Indication** (p. 30)
- u** **Z.MIC Indication** (Menu OSD: p. 104)
This display appears when ZOOM-MIC is set to ON.
- v** **Light Indication** (p. 8)
This display appears when LIGHT is set to ON.
- w** **WIND-CUT Indication** (Menu OSD: p. 104)
This display appears when WIND-CUT is set to ON.
- x** **Progressive Indication** (Menu OSD: p. 104)
This display appears when PROGRESSIVE is set to ON.

Electronic Viewfinder/LCD Monitor Indications

PHOTO Mode

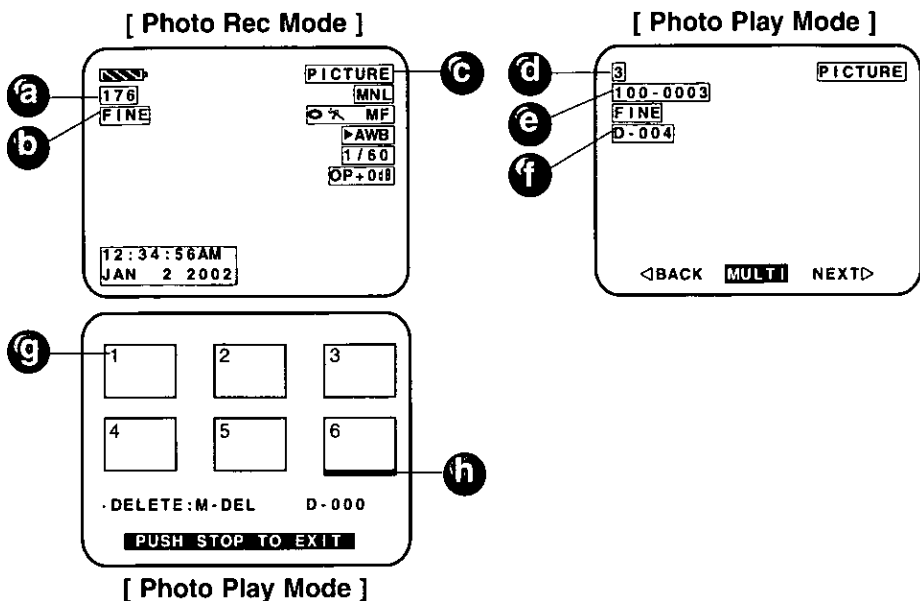

(a) Image Page Remaining Indication
(p. 47)

- Image pages left in selected mode.
- "000" flashes when memory is full.
- Memory capacity provided all pictures are taken in the same mode:
 - "NORMAL" mode
 - Approx. 70 images (Supplied 8 MB Memory Card)
 - "FINE" mode
 - Approx. 30 images (Supplied 8 MB Memory Card)

(b) REC MODE

- NORMAL or FINE mode.
- Image Size:
 - "NORMAL" mode
 - 640 x 480 pixels
 - "FINE" mode
 - 1 280 x 960 pixels

(c) Recording Mode
POWER is set to PICTURE.

(d) Directly/Image Number

(e) DCF NO. (Design rule for Camera File system) Indication
(Menu OSD: p. 107)

(f) DPOF Indication (p. 53)

(g) Multi Image Playback page number

(h) Currently selected image is underlined in green

Index of Controls

Front View

Built-in Twin Capsule 2-Way Microphone System

Lens

Remote Sensor
p. 8.

Built-in Light
pp. 8, 91.

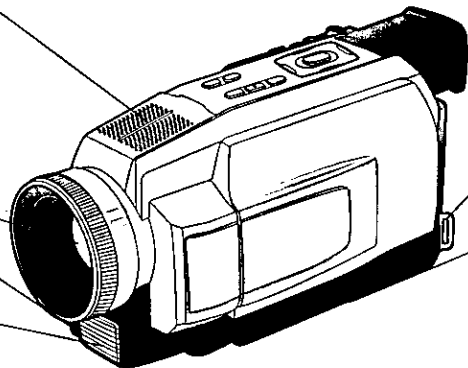

Shoulder Strap Attachment Ring
p. 7.

BATT RELEASE
pp. 13, 14.

Side View

JOG KEY
pp. 15, 16.

M.FOCUS DIAL
p. 28.

M-CARD EJECT
p. 12.

POWER (VCR•OFF•CAMERA•M-CARD)
pp. 10, 11, 12.

M-CARD Lock
p. 12.

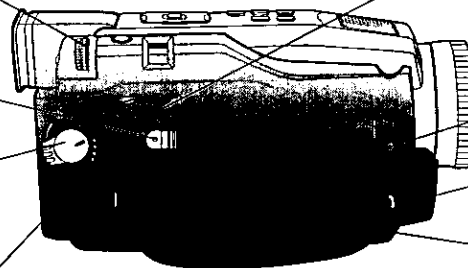

M-CARD Door
p. 12.

Built-in Speaker
p. 32.

Shoulder Strap Attachment Ring
p. 7.

Hand Strap
p. 7.

Rear View

Cassette Compartment Cover
p. 7.

LCD (Liquid Crystal Display) Monitor
pp. 10, 11, 18, 31.

LCD-OPEN
pp. 10, 11, 18, 31.

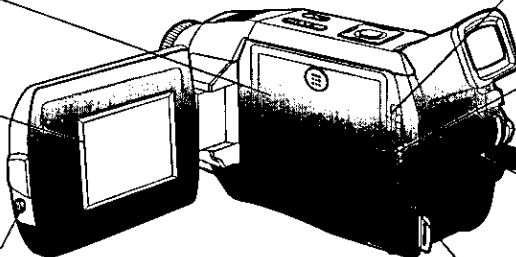

TAPE EJECT
pp. 7, 10.

DV Input/Output (i.LINK) Connector
pp. 46, 69.

DC IN Terminal
p. 14.

USB Terminal
pp. 57, 72, 78.

Index of Controls

Rear View

Electronic Viewfinder (EVF)
p. 11.

MENU
pp. 15, 16.

A/V Output Connector
pp. 38, 78.
PHONE
p. 31.

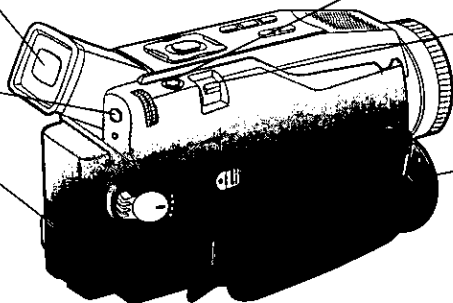

PHOTOSHOT
pp. 19, 47, 48.

POWER ZOOM
pp. 20, 39.
VOLUME
p. 32.

Lens Cap
p. 7.

Top View

FOCUS
p. 28.

AUTO/MANUAL
pp. 27-30.

FADE
p. 24.
REC
p. 46.

LIGHT
p. 8.

EIS
p. 41.

REW
pp. 11, 31.
RECORDING CHECK
p. 21.

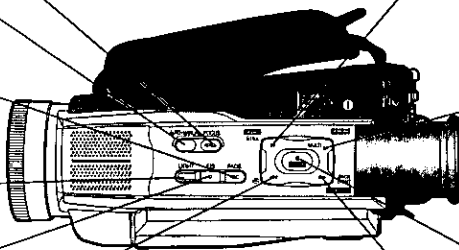

PAUSE
pp. 33, 44, 46.
CAMERA STILL
p. 25.
M-DEL
pp. 50, 51, 52.

PLAY
pp. 11, 31.
M-PLAY
pp. 49, 50.
MULTI
p. 37.

STOP
pp. 11, 31.
M-STOP
pp. 49-52.

FF
p. 33.
BACK LIGHT
p. 22.

Back View

Vision Adjustment Control
pp. 11, 17.

POWER Lamp
p. 17.

REC/PAUSE
pp. 11, 17.

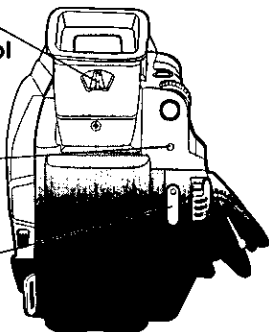

Underside View

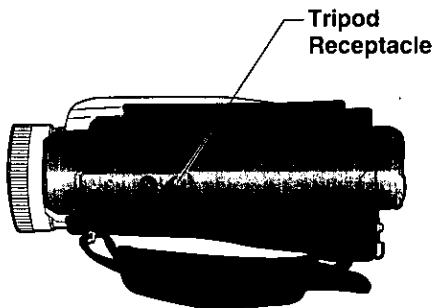

For Your Information

AC Adaptor

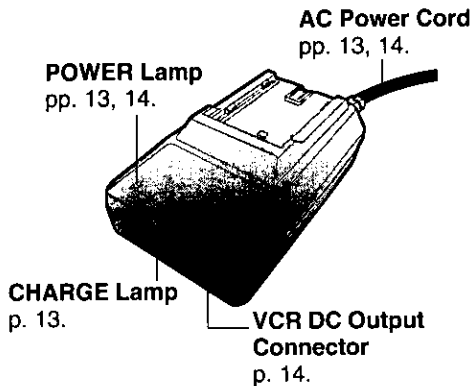

CAUTION:

This unit will operate on 110/120/220/240 V AC. An AC plug adaptor may be required for voltages other than 120V AC. Please contact either a local or foreign electrical parts distributor for assistance in selecting an alternate AC plug. We recommend using the accessory power plug adaptor (VJSS0070) in an area which has special AC outlets.

Remote Control (Optional)

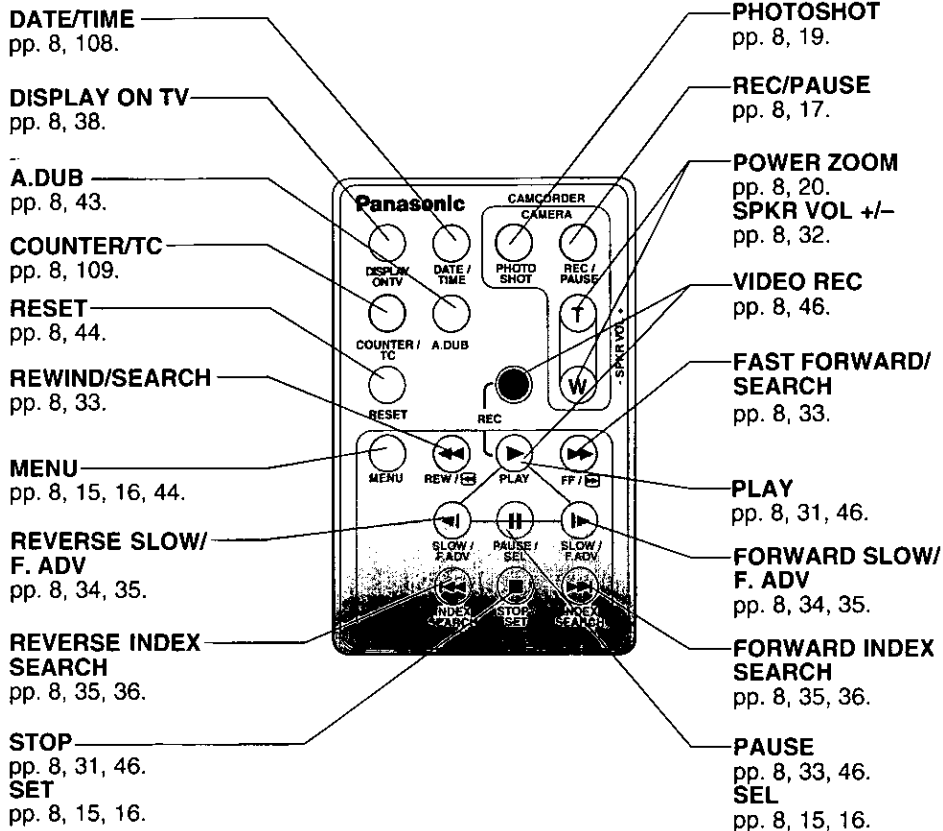

- A**
 AC Adaptor ... 6, 13, 14, 89
 Accessories (Optional) . 89
 Accessories (Supplied)... 6
 A/V Cable 6, 38, 78
 Audio Adaptor 6, 78
 Audio Dubbing 43, 44
 Audio/Video Fade In/Out
 24
- B**
 Backlight 22
 Battery Pack . 6, 10, 13, 89
 Battery Remaining
 Indication 108
 Battery Warning 96
 Before Requesting Service
 94, 95
 Blank Search 32
 Built-in Light 8
- C**
 Card PhotoShot 47
 CD-ROM 6, 55
 CINEMA Mode 22
 Cleaning Care for
 Video Heads 94
 Clock Battery 96
 Clock Set 15
 Concerning the Memory
 Card (Optional) 91
 Connecting Earphone ... 31
 Copying from Digital
 Equipment 46
 Copying your Tapes 45
- D**
 Date and Time Indication
 108
 DC Power Cable . 6, 14, 89
 Delete All Image Pages ... 51
 Delete Specific Images 50
 DEW Indication 96
 Digital E.I.S. 41
 Digital Functions 42
 Digital PhotoShot™ Mode
 19
 Digital Video Cassette Tape
 6
 Digital Zoom 39, 40
 DV Interface Cable (i.LINK)
 46, 69, 89
 DPOF Setting 53
- E**
 Easy Cassette Eject 7
 Erase Protection Tab 6
 EVF/LCD Monitor Indications
 108-111
- F**
 Fast Forward/Rewind Check .. 33
 Focus 28
 Format the Memory Card 52
 Frame by Frame Advance ... 35
- H**
 Hand Strap 7
 High Speed Shutter 29
 How to remove the Sensor
 tag 6
- I**
 Important Safeguards 3
 Index of Controls . 112-114
 Index Search 35, 36
 Iris 30
- J**
 Jog Search 36
- L**
 LCD/EVF Setting 18
 Lens Cap 6, 7, 17
 Lens Cap Strap 6, 7
 Limited Warranty 98
- M**
 MagicPix™ Images 40
 Memory Counter 109
 Memory Stop Editing 44
 MENU OSD 104-107
 Memory Card (Optional)
 6, 12, 89
- O**
 On-Screen Display (OSD)
 96, 97
- P**
 Palmcorder File Converter
 75, 76
 Palmcorder USB Device
 Driver/SD Drive 72-74
 Photo Title 26
 PHOTOVU/MPEG4 Movie
 Messenger™ System
 57-68
 Picture in Picture (PiP)
 25
 Playback Still Images ... 49
 Playback using the LCD
 Monitor 31
 Precautions 4
 Program AE 23
 Progressive PhotoShot™
 Mode 19
- Q**
 Quick Guide 10, 11, 12
- R**
 Rapid Visual Search 33
 Recording Check 21
 Recording images From
 a Tape 48
 Recording Still Pictures ... 21
 Remote Control (Optional)
 6, 8, 9, 89, 114
 Remote Controlling Two
 Palmcoders 9
 Repeat Playback 32
 Replacing the Bulb 91
 Request for Service Notice 97
- S**
 Safety Precautions 2
 Self Recording 21
 Servicenter List 99
 Shoulder Strap 6, 7
 Simple Recording ... 17, 18
 Slow Motion Playback .. 34
 Spanish Quick Use Guide
 Specifications 100-103
 Specifications 93
 STILL Picture 33
 Strobe Multi Mode 37
 Supplying Power 13, 14
- T**
 Table of Contents 5
 Tape Remaining Indications
 108
 Tape Speed 6
 Tape Warning 96
 Transferring Your Images
 (Macintosh) 87, 88
 Transferring Your Images
 (Windows) 54, 55, 56
 Transferring Your Images
 (i.LINK) (Windows) .. 69-71
- U**
 USB Cable 6, 57, 72, 78
 Using the Palmcorder Menu ... 16
- V**
 Variable Speed Search . 34
 VHF Connecting Cable 45
 Volume Display 32, 108
- W**
 Warning Indications 86
 Web Camera 77-85
 White Balance 27
 WIND-CUT 30
- Z**
 Zoom In/Out 20
 Zoom Microphone 20

Panasonic Consumer Electronics Company,
Division of Matsushita Electric Corporation of America
One Panasonic Way Secaucus, New Jersey 07094

Panasonic Sales Company ("PSC"),
Division of Matsushita Electric of Puerto Rico, Inc.
Ave. 65 de Infanteria, Km. 9.5 San Gabriel Industrial Park Carolina,
Puerto Rico 00985



Printed in Japan
LSQT0574A
S0102A0